

TAG TECHNICAL NOTE NUMBER 3

The Ventilated Improved Double-Pit Latrine: A Construction Manual for Botswana

John van Nostrand and James G. Wilson

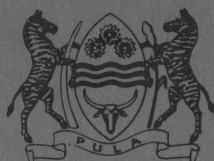

A joint contribution of the Government of Botswana, the United Nations Development Programme, and the World Bank to the International Drinking Water Supply and Sanitation Decade.

TAG TECHNICAL NOTE NUMBER 3

The Ventilated Improved Double-Pit Latrine: A Construction Manual for Botswana

John van Nöstrand and James G. Wilson



A joint contribution of the Government of Botswana, the United Nations Development Programme and the World Bank to the International Drinking Water Supply and Sanitation Decade.

APRIL 1983

Copyright © 1983
International Bank for Reconstruction and Development/
The World Bank, 1818 H Street, N.W.,
Washington, D.C. 20433, U.S.A.

Preface

This paper is one of a series of informal Technical Notes prepared by TAG¹ on various aspects of water supply and sanitation programmes in developing countries. The papers were originally prepared as internal discussion documents; their wider distribution does not imply endorsement by the sector agencies, government, or donor agencies concerned with the programmes, nor by The World Bank or the United Nations Development Programme. Comments and suggestions on the papers should be addressed to the Project Manager, UNDP Project INT/81/047, Transportation and Water Department, The World Bank, 1818 H Street, N.W., Washington, D.C. 20433.

Richard N. Middleton
Project Manager

Summary

This construction manual has been prepared as a field manual for Self-Help Housing Agency (SHHA) Technical Assistants (TAs) charged with assisting urban householders and contractors in the construction in Botswana of REC II latrines. The REC II is a ventilated improved double-pit latrine, particularly suitable for providing affordable on-site sanitation in urban areas. The booklet sets out current recommended construction procedures and supervision guidelines, and contains extensive construction drawings and details.

Acknowledgements

The authors wish to acknowledge, with thanks, the advice and assistance they received from Botswana's Ministry of Local Government and Lands, and the Self-Help Housing Agencies of Gaborone, Francistown and Selebi-Phikwe Town Councils.

¹ITAG: Technology Advisory Group established under the United Nations Development Programme Global Project GLO/78/006 (renumbered on January 1, 1982; now UNDP Interregional Project INT/81/047, "Development and Implementation of Low-Cost Sanitation Investment Projects"), executed by The World Bank.

Contents

1. Introduction	4
2. Principles of the Ventilated Improved Double-Pit (VIDP) Latrine	5
3. Inspecting the Construction of the Substructure	8
A. Substructures Built in Unstable Soils	9
B. Substructures Built in Stable Soils	15
4. Inspecting and Assisting in the Construction of the Superstructure	22
A. Concrete Block Superstructure	23
B. Alternative Superstructure	26
5. Monitoring the Ventilated Improved Double-Pit (VIDP) Latrine	29
Appendices	33
I Substructure in Unstable Soils: List of Materials	33
II Concrete Block Superstructure: List of Materials	34
III Substructure in Unstable Soils: Plans and Section	35
IV Substructure in Stable Soils: Plan and Section	37
V Coverslabs and Concrete Cap: Plans, Sections and Bending Schedule	38
VI Concrete Block Superstructure: Plans, Front Elevation and Section	42
VII Latrine Inspection Record Sheet	45

1. Introduction

This booklet is intended to serve as a field manual for Self-Help Housing Agency (SHHA) Technical Assistants (TAs) charged with inspecting and assisting in the construction of what are known in Botswana as “Revised Earth Closet Type II (REC II)” latrines. These are ventilated improved double-pit latrines which are particularly suitable for use in urban areas. In addition to assisting residents of Self-Help Housing Areas in building their homes, the SHHA TAs have three major responsibilities in the field of sanitation:

first, inspecting the construction of substructures which are built by private contractors;

second, supervising, and providing assistance to, individual plot-holders in the construction of their superstructures; and

third, monitoring the use of the latrines after construction is finished.

The success of the REC II latrines depends, to a very large degree, on the diligence and care with which the SHHA TAs fulfil these responsibilities.

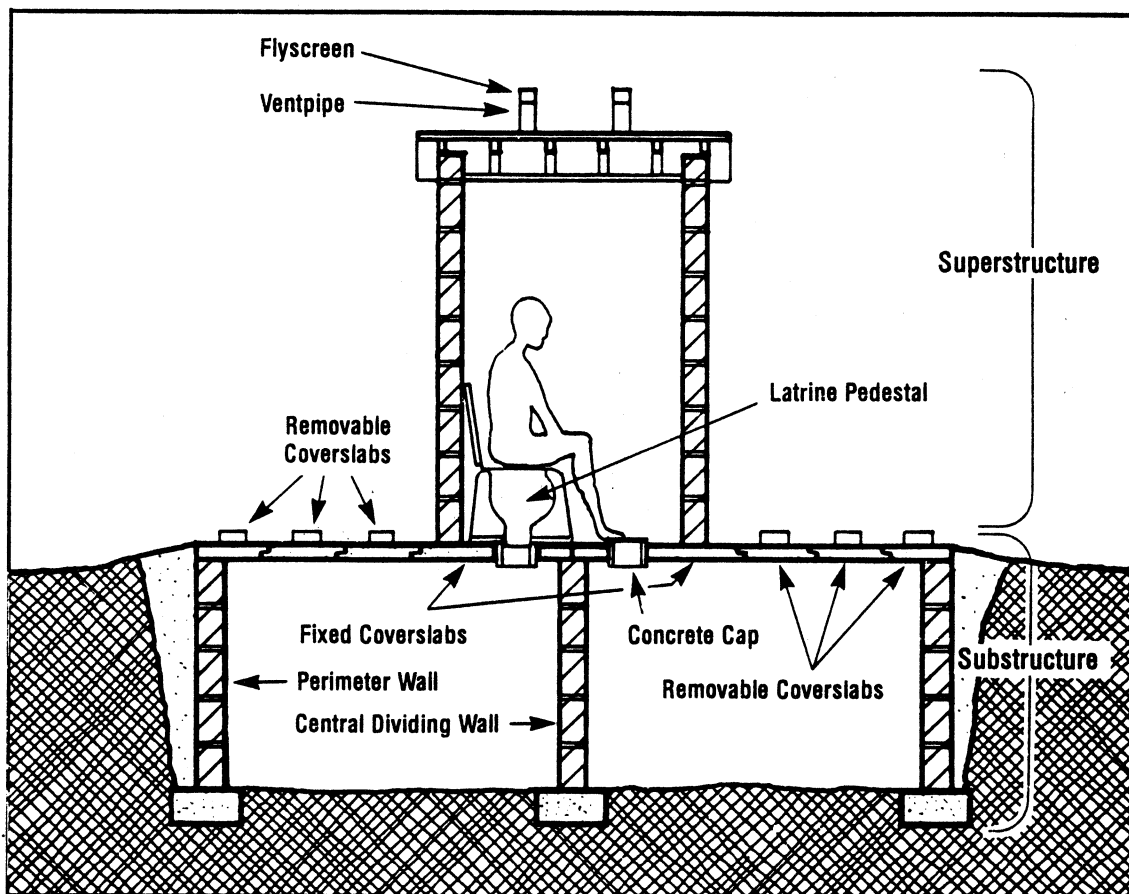

The REC II (VIDP) Latrine

2. Principles of the Ventilated Improved Double-Pit (VIDP) Latrine

The Revised Earth Closet Type II (REC II) latrine was first introduced in Botswana in 1978. The initial design was derived from one which had been previously tested in England by the Building Research Establishment. The REC II is more popularly known as a “ventilated improved double-pit (VIDP)” latrine. Since 1978, over 2500 REC II units have been built in Botswana and another 7000 are currently under construction. Proposed development plans call for another 6000 to be built within the next five years, and it is clear that this is the preferred sanitation system for most urban areas in the country.

The design of the REC II unit is based on some fundamental principles of operation which the Technical Assistant must keep in mind throughout the construction period and thereafter.

Principle 1: Two Pits

The REC II design is derived from the traditional rural pit latrine which has been adapted and improved to meet more complex urban conditions. While it is similar in some ways, there are important differences. In rural areas, when pits become full, they are covered permanently and the superstructure is relocated. This is not usually possible in urban areas where plots are smaller and residents prefer a more solid superstructure which is not readily moved. For these reasons, the REC II has been developed. It provides two shallower pits, placed side by side and straddled by a single superstructure. Instead of moving the entire superstructure when the pit is full, the plot-holder simply moves the portable glass-fibre reinforced plastic (grp) pedestal from one pit to the other and recaps the unused hole. The REC II is a dry latrine, and is not designed to receive liquids other than urine and small amounts of water. These liquids soak away into the subsoil below ground level.

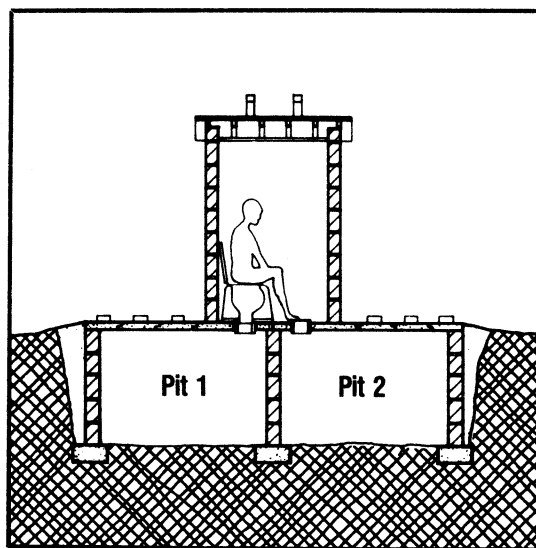

**The REC II (VIDP) Latrine:
Cross-Section**

Principle 2: The Ventpipes

Both pits are ventilated by separate black polyvinyl chloride (pvc) ventpipes, capped with flyscreens, which serve a dual purpose. First, they carry the foul air out of the pits and away from the superstructure. This occurs mainly because wind across the ventpipes sucks fresh air through the latrine seat and foul air out the ventpipe. It also occurs because the air in the ventpipes rises when heated by direct sunlight. Second, the ventpipes serve as insect traps. Flies and other insects will only fly into the light. Thus, when they travel out of the dark pit and up a ventpipe, they are trapped by the flyscreen, die and fall back into the pit.

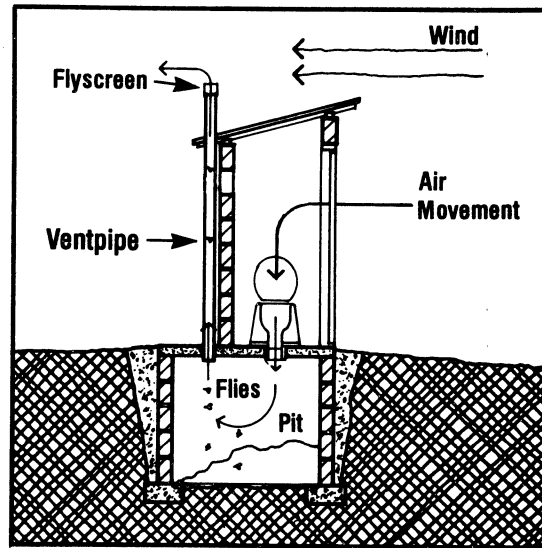

How the Ventpipes Work

Principle 3: The Latrine Pedestal

The portable grp pedestal was originally designed in direct collaboration with the residents of Self-Help Housing Areas in Gaborone. After it was established that people prefer to sit, particular attention was paid to the size of the pedestal's upper and lower openings. The upper opening is large enough to minimize fouling of the bowl, while the lower opening is small enough to encourage parents to let their children use the pedestal without fearing they will fall in. Thus, the bowl is designed for, and should be used by, all age groups.

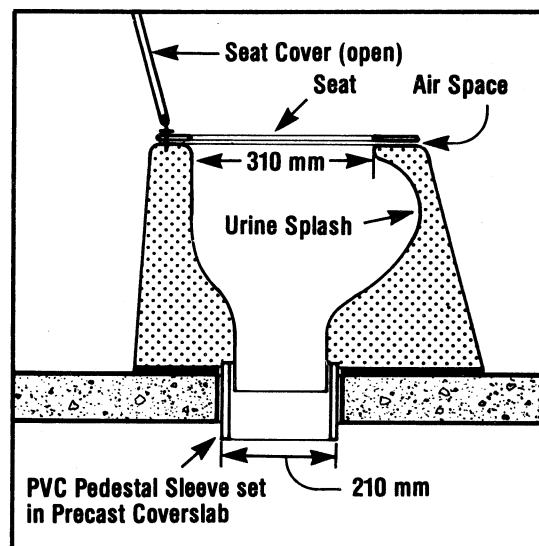

The Latrine Pedestal

Principle 4: Improved Maintenance

The provision of two pits gives greater flexibility in maintenance. A pit will fill, under normal conditions, in about four years. It should then stand for at least one year. This allows time for the waste material to dry out and decompose, so that it may be more easily removed and not pose a health hazard. The full pit may then be emptied at any time during the next three years, while the other pit is in use. This gives the Town Council ample time to arrange for the emptying. It is most important that plot-holders do not use both pits at the same time.

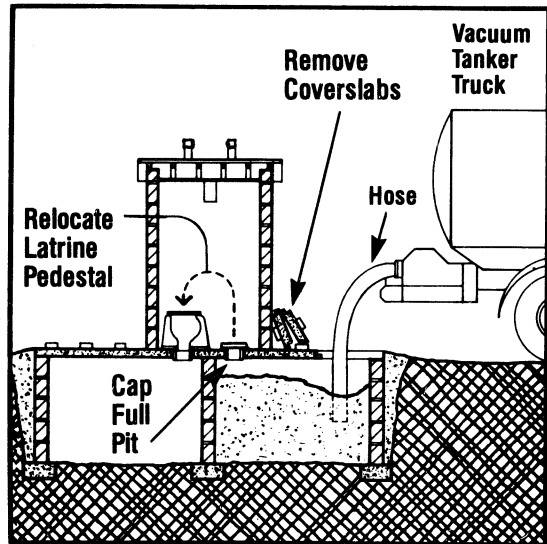

Emptying the Pit

Principle 5: Self-help Construction

Responsibility for constructing the superstructure lies with the plot-holder. He must complete it within a specified time period (currently, 3 months) in order to retain the right to occupy the plot. Every effort must be made by the TAs to assist the plot-holder in fully completing his superstructure as soon as possible after the plot is allocated.

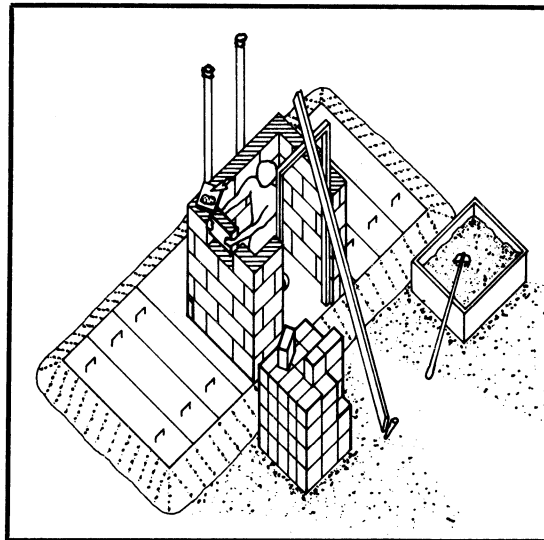

Constructing the Superstructure

3. Inspecting the Construction of the Substructure

This section presents a step-by-step outline of the construction programme followed by private contractors who are hired by Town Council to build the REC II latrine substructures. It highlights, in particular, the duties of the SHHA Technical Assistant (TA) who is responsible for inspecting the work and reporting on its progress to the SHHA Senior Technical Officer (STO) or the SHHA Senior Works Foreman. Regular visits should be made to the plot during the construction period, and progress recorded on Latrine Inspection Record Sheets (see Appendix VII), to be supplied by individual SHHAs.

Before entering the field each day, the TA must ensure that he has the necessary equipment required to complete his task. This includes the following:

- A Spirit Level
- A Copy of the Contract Drawings
- A Steel Tape Measure
- A Notebook with Carbon Paper, and a Pen
- Latrine Inspection Record Sheets
- A Mallet or Hammer
- Steel Stakes
- A Satchel or Carrying Bag

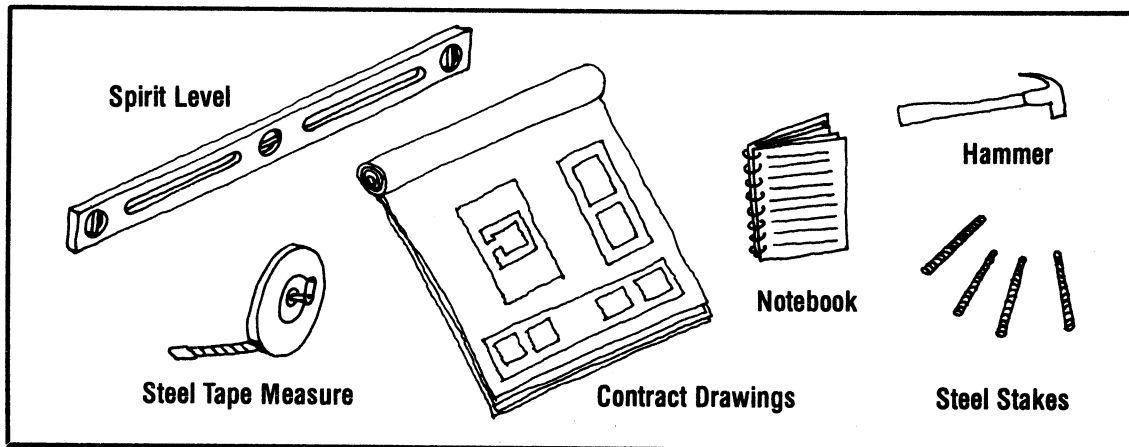

Field Equipment

The TA must keep a clear written account of all his observations, dated and entered in the notebook. In the event that he discovers a deficiency on the part of the contractor, he should inform the contractor in writing, give one copy to the STO, and retain one copy for his own records. He should avoid disputes with the contractor or his staff on the job site.

3A. Substructures Built in Unstable Soils

Step 1: Location and Staking

The TA is responsible for locating and staking the outline of the substructure on the plot, prior to the arrival of the contractor. This should be carried out in close collaboration with the plot-holder, and ensures that the latrines are located in conformity with Ministry and Town Council regulations.

The substructure should be located at one of the rear corners of the plot, parallel to the plot boundary and no closer than 2750 mm to it. This leaves space for access to the latrines by Council maintenance crews and ensures that one latrine is at least 5 metres from the next. The staked area must measure 4450 mm by 2000 mm.

In rocky areas, it is preferable that, following the staking, the TA arranges to have two 1.5-metre-deep hand auger holes dug at the centre of the pit to test for rock. If rock or unpickable soils are found, the substructure must be relocated along the rear boundary. The TA should consult with the STO before relocating the latrine away from the rear plot boundary.

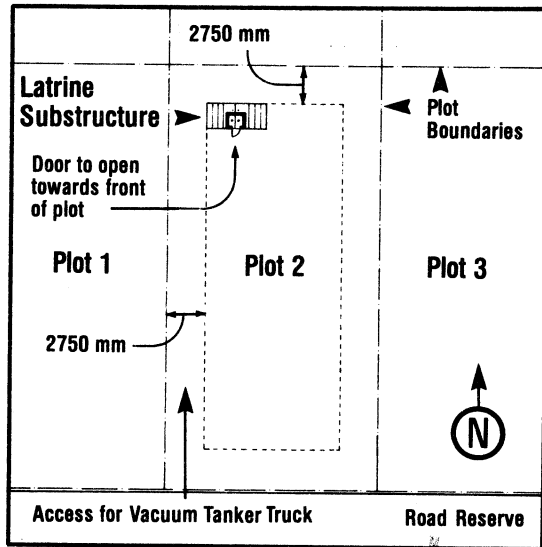

Locating the Latrine

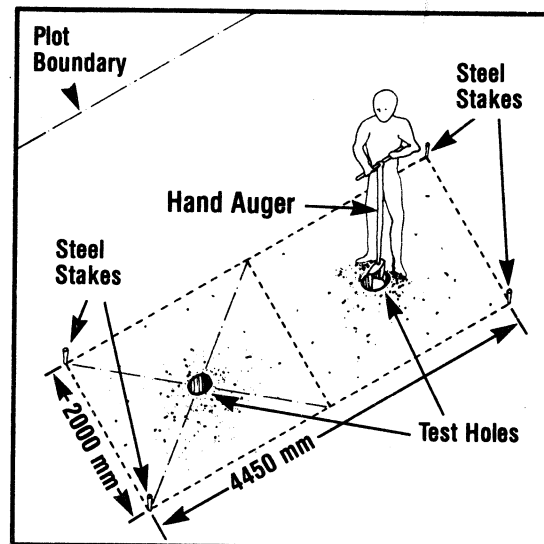

Testing for Rock

Step 2: Orientation

Before construction begins, the TA must ensure that the contractor is aware of the proper orientation for the latrine.

First, the latrine should be oriented so that the maximum amount of direct sunlight reaches the black ventpipes. On calm days, proper ventilation of the pits relies on the air inside the ventpipes heating up, rising and sucking the foul air upwards. Preferably, therefore, the ventpipes should face northwards. Where this is difficult or impossible to achieve, the ventpipes should face eastwards or westwards. They should not face southwards. Where conflicts arise, the TA should consult the STO.

Second, the TA must ensure that the future door to the superstructure is not directly visible to either passersby or neighbouring plots. Preferably, the door should face the plot-holder's future house. If the door is not properly located, plot-holders may refuse to use their latrine.

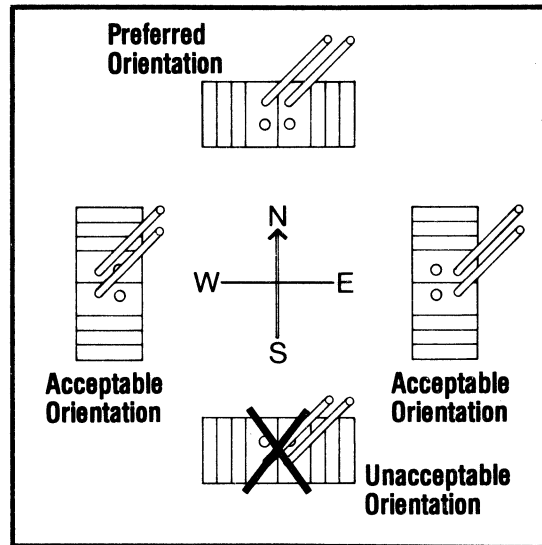

Orientation of Ventpipes

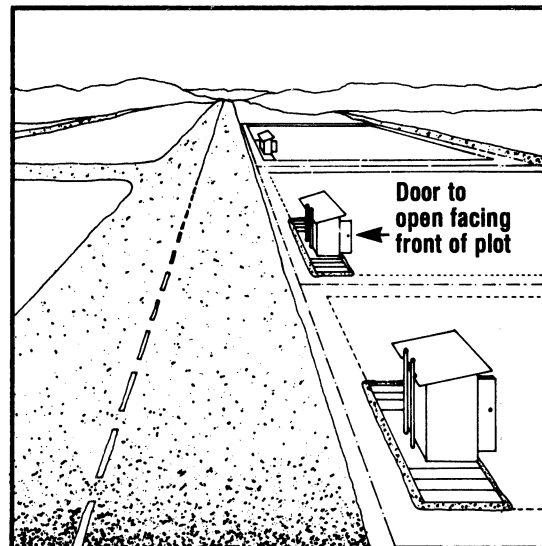

Orientation of Doors for Privacy

Step 3: Excavation and Foundation

The contractor commences construction of the substructure by excavating the pit defined by the stakes, digging a perimeter trench and pouring a concrete strip foundation.

In inspecting the excavation and the foundation, the TA must ensure that:

1. Soils at the bottom of the pit are firm and form a good foundation for the blockwork.
2. The concrete mix being used in the foundation is in the proportion of 1 cement to 2 sand to 4 stone.
3. The concrete is covered and kept moist for at least 3 days in order to allow it to cure properly.
4. The top of the foundation is no less than 1250 mm below natural ground level.
5. The overall dimensions of the foundation are correct and the top of the foundation is level.
6. Earth removed from the pit is evenly distributed around the substructure or removed from the site. If the soil is left in one large pile, it may cause accumulation of rainwater which could flood the pit.

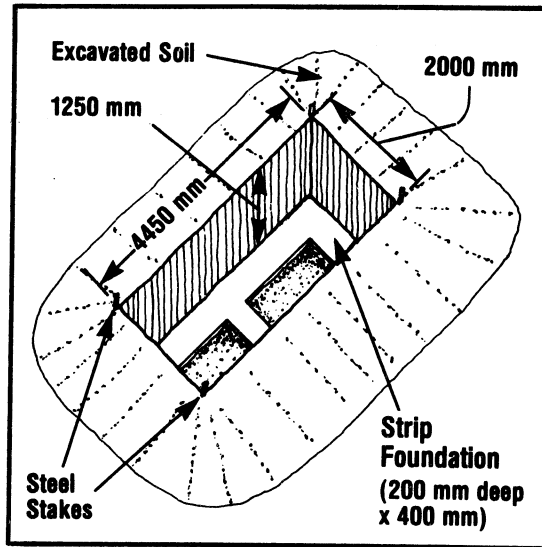

Excavation and Foundation

Step 4: Blockwork

Once the concrete foundation has cured for at least 3 days, the contractor may commence construction of the concrete-block walls. The concrete should be kept damp during the curing period with, for example, wet hessian or sand.

In inspecting the blockwork, the TA must ensure that:

1. 150 mm solid blocks are used throughout, and are of good quality.
2. The mortar mix is 1 cement to 4 sand.
3. All joints in the central dividing wall are well sealed.
4. All *vertical* joints in the perimeter walls are left open (to a width of 10 mm) except for the top two courses which must be fully sealed to prevent insects and rain water from entering the pits.
5. The walls are at least five courses high and, when complete, extend at least 100 mm above natural ground level.
6. When the blockwork is completed, the earth at the bottom of the pit is loosened with a pick, and all surplus mortar is removed.

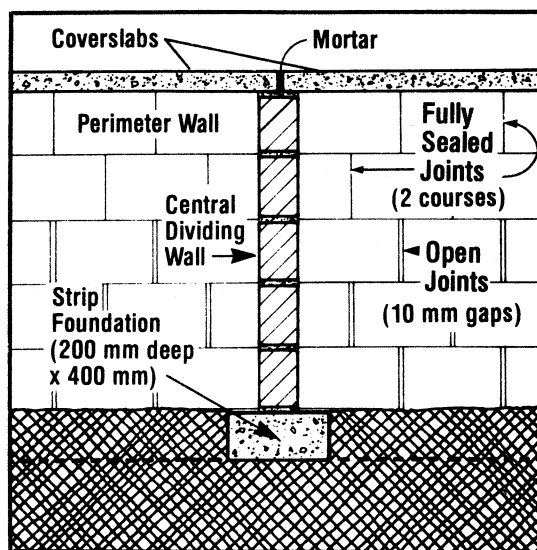

Section through Central Dividing Wall

Step 5: Coverslabs

Usually, the reinforced concrete coverslabs are manufactured off-site and delivered by a second contractor. Following completion and proper curing, for at least 3 days, of the block walls, the contractor may commence to lay the coverslabs. The two central slabs are fixed permanently in place. The six outer slabs are left loose so that they may be removed in future to facilitate emptying of the pit.

In inspecting the slabwork, the TA must ensure that:

1. On delivery, the slabs are in good condition. He should check for flaking, chipping, cracks, exposed reinforcing steel, and, in particular, damage to the overlapping edges which may prevent them from being sealed properly. Also, he should check that the angle irons and the pedestal and vent-pipe holes are correctly located and oriented.
2. Following fixing of the two central slabs, mortar is applied to the exposed block lip to raise it to the level of the underside of the central slabs. This mortar should be smooth-finished, preferably with a steel trowel, and allowed to set for 24 hours.
3. A single strip of non-setting rubberized sealing compound is applied to one edge of all remaining joints between the six outer slabs and the inner slabs or blockwork (this prevents the movement of insects to and from the pit and makes it airtight and odour-free). The outer slabs are then placed in position and butted tightly together.

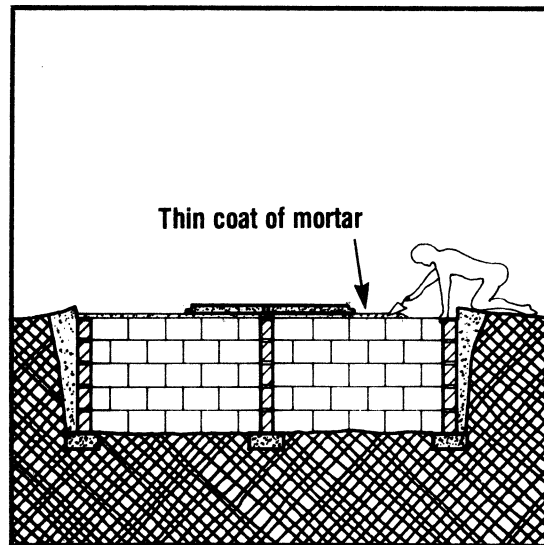

Levelling for Outer Slabs

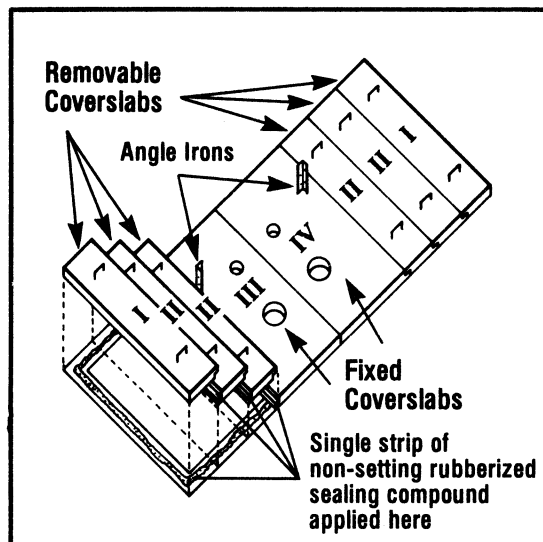

Laying the Coverslabs

Step 6: Backfill

Once the slabs are in place, the contractor may commence to backfill. In inspecting this operation, the TA must ensure that:

1. Backfill is properly completed.
2. Backfill is sloped away from the upper edge of the outer slabs to carry rainwater away from the latrine.
3. The backfill against the lower courses of open blockwork drains well. A permeable material such as gravel should be used.
4. The backfill against the top two courses of closed blockwork does not drain freely. An impermeable material such as clay should be used.
5. In order to prevent damage by rainwater, about 100 mm of the top surface of the backfill is composed of cement-stabilized material mixed in the proportion of 1 cement to 10 sand or soil.

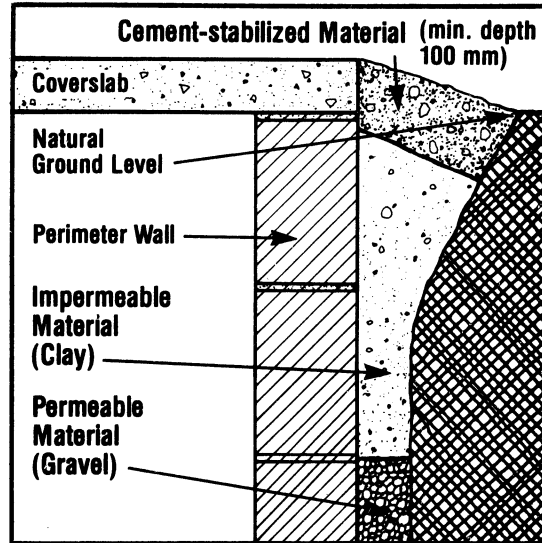

Backfill at Perimeter Wall

3B. Substructures Built in Stable Soils

Step 1: Location and Staking

The TA is responsible for locating and staking the outline of the substructure on the plot, prior to the arrival of the contractor. This should be carried out in close collaboration with the plot-holder, and ensures that the latrines are located in conformity with Ministry and Town Council regulations.

The substructure should be located at one of the rear corners of the plot, parallel to the plot boundary and no closer than 2750 mm to it. This leaves space for access to the latrine by Council maintenance crews and ensures that one latrine is at least 5 metres from the next. The staked area must measure 4200 mm by 1750 mm (i.e., the outer corners of the ringbeam).

In rocky areas, it is preferable that, following the staking, the TA arranges to have two 1.5-metre-deep hand auger holes dug at the centre of the pit to test for rock. If rock or unpickable soils are found, the substructure must be relocated along the rear boundary. The TA should consult with the STO before relocating the latrine away from the rear plot boundary.

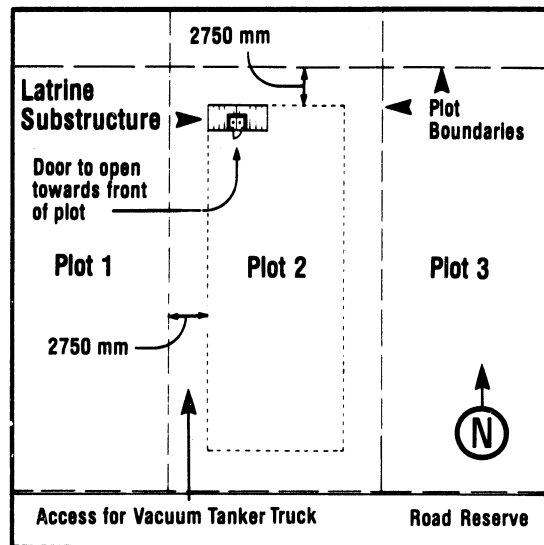

Locating the Latrine

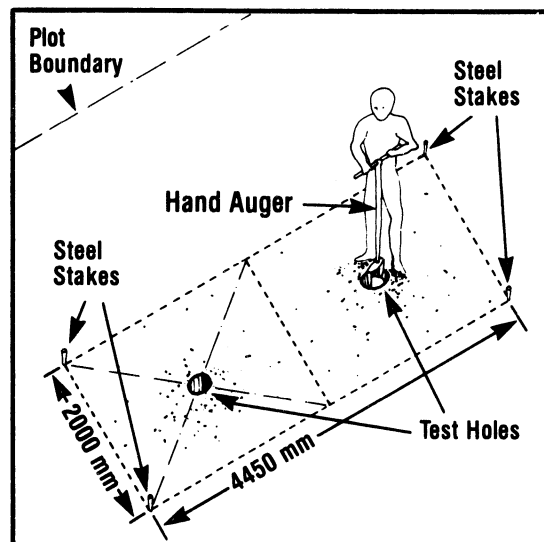

Testing for Rock

Step 2: Orientation

Before construction begins, the TA must ensure that the contractor is aware of the proper orientation for the latrine.

First, the latrine should be oriented so that the maximum amount of direct sunlight reaches the black ventpipes. On calm days, proper ventilation of the pits relies on the air inside the ventpipes heating up, rising and sucking the foul air upwards. Preferably, therefore, the ventpipes should face northwards. Where this is difficult or impossible to achieve, the ventpipes should face eastwards or westwards. They should not face southwards. Where conflicts arise, the TA should consult the STO.

Second, the TA must ensure that the future door to the superstructure is not directly visible to either passersby or neighbouring plots. Preferably, the door should face the plot-holder's future house. If the door is not properly located, plot-holders may refuse to use their latrine.

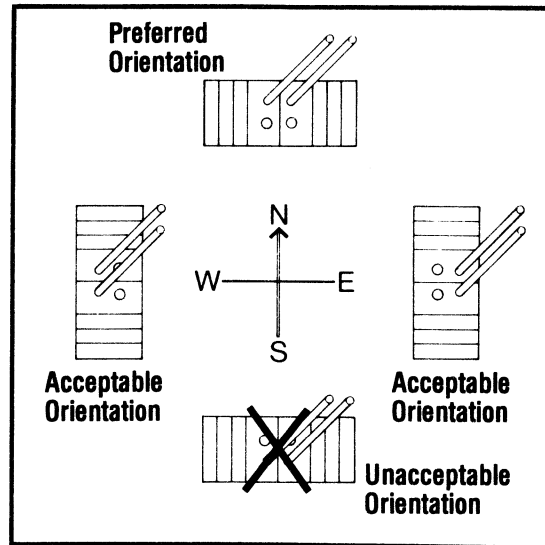

Orientation of Ventpipes

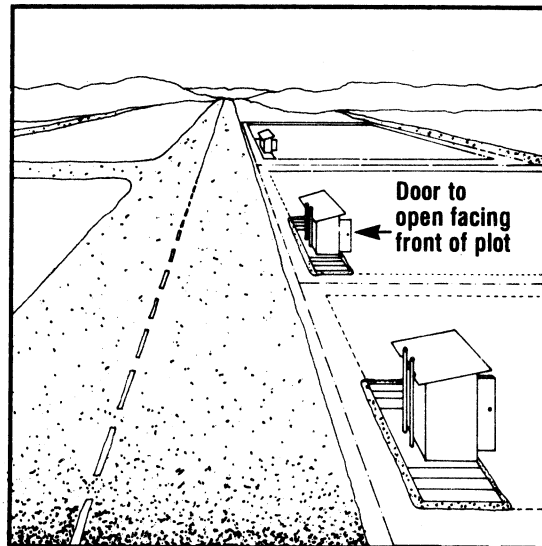

Orientation of Doors for Privacy

Step 3: Ringbeam

The contractor commences construction by excavating a shallow perimeter trench, erecting formwork, fixing steel reinforcing bars and pouring a concrete ringbeam. The ringbeam should measure at least 250 mm by 250 mm square. In inspecting these works, the TA must ensure that:

1. The reinforcing steel core is connected throughout and correctly located so that it will lie at the centre of the ringbeam. The steel must be raised off the bottom of the trench, and the bottom and top covers should be 25 mm of concrete.
2. The concrete being used is mixed in the proportion of 1 cement to 2 sand to 4 stone, not too wet, and well compacted.
3. The concrete is covered and kept moist for at least 3 days in order to allow it to cure properly.
4. The ringbeam is correctly aligned, dimensioned and squared.
5. The ringbeam projects at least 100 mm above natural ground level.

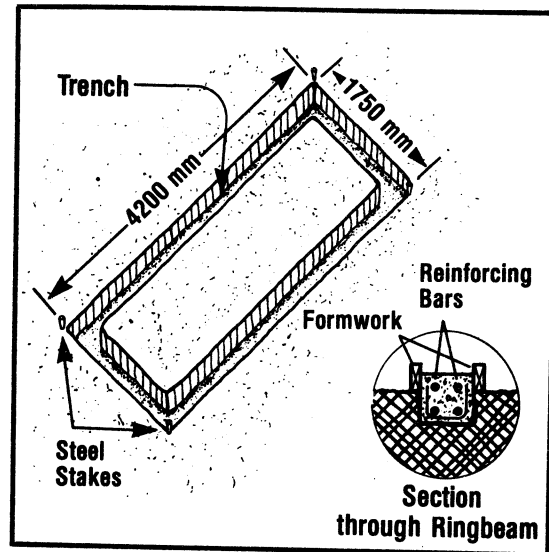

The Ringbeam Trench

Step 4: Excavation

Following completion and proper curing of the ringbeam, for at least 3 days, the contractor excavates the pit. In inspecting this operation, the TA must ensure that:

1. The pit lies 125 mm inside the ringbeam, thus ensuring that the soil around the ringbeam remains undisturbed. The clear width of the pit must be 1000 mm.
2. The dimension from top of ringbeam to bottom of pit is not less than 1950 mm.
3. The sides of the pit are sloped (not more than 1 in 20) and are hammered or compacted.
4. Earth removed from the pit is evenly distributed around the substructure or removed from the site. If the soil is left in one large pile, it may cause accumulation of rainwater which could flood the pit.

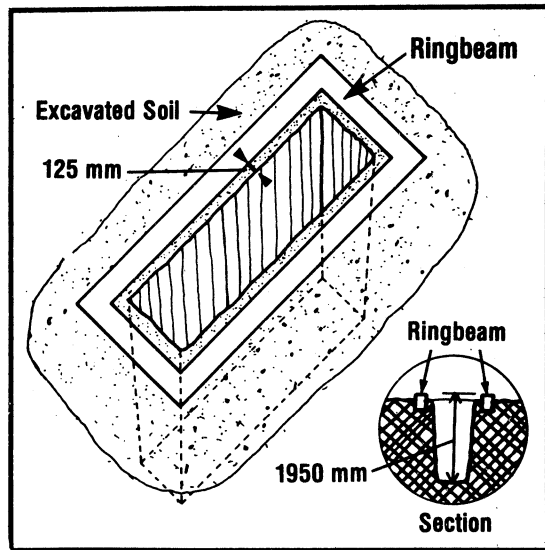

Excavation and Ringbeam

Step 5: Blockwork

Following excavation of the pit, the contractor will excavate a trench and pour a single, strip foundation to support the central dividing wall. This wall can be constructed after the foundation has properly cured for 3 days. In inspecting these works, the TA must ensure that:

1. The foundation and central dividing wall are keyed into the sides of the pit so that the wall, when completed, is *flush* against the underside of the ringbeam.
2. The concrete mix for the footing is 1 cement to 2 sand to 4 stone.
3. The wall is constructed of 150 mm solid block sealed throughout with mortar mixed at 1 cement to 4 sand.
4. The central dividing wall is correctly aligned, perfectly perpendicular to the ringbeam and vertical.
5. The backfill around the ends of the central dividing wall is recompact with cement-stabilized material, mixed at 1 cement to 10 sand or soil.
6. When the blockwork is completed, the earth at the bottom of the pit is loosened with a pick, and all surplus mortar is removed.

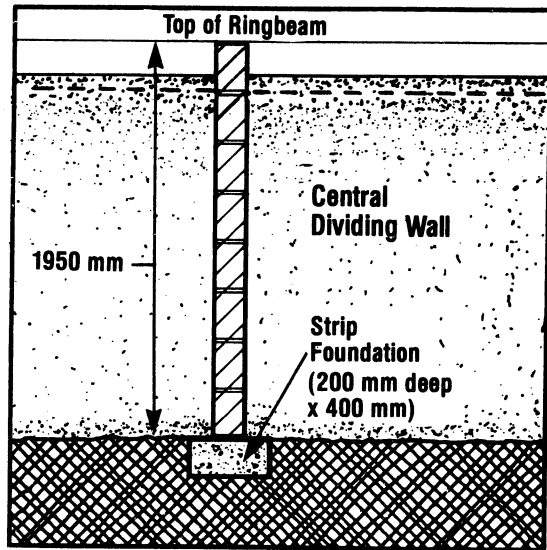

Section through Central Dividing Wall

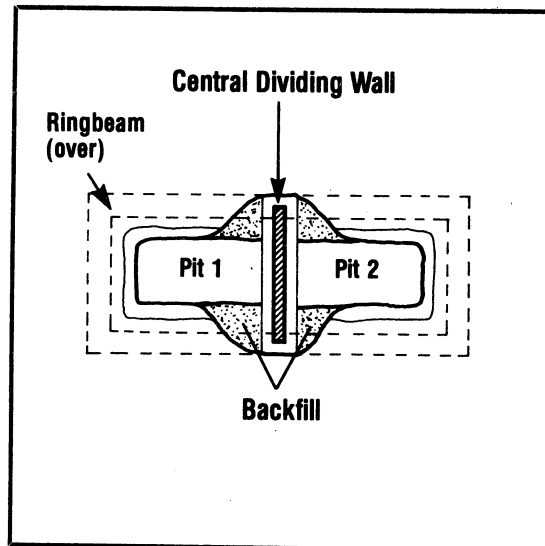

Backfill around Central Dividing Wall

Step 6: Coverslabs

Usually, the reinforced concrete coverslabs are manufactured off-site and delivered by a second contractor. Following completion and proper curing, for at least 3 days, of the block wall, the contractor may commence to lay the coverslabs. The two central slabs are fixed permanently in place. The six outer slabs are left loose so that they may be removed in future to facilitate emptying of the pit.

In inspecting the slabwork, the TA must ensure that:

1. On delivery, the slabs are in good condition. He should check for flaking, chipping, cracks, exposed reinforcing steel, and, in particular, damage to the overlapping edges which may prevent them from being sealed properly. Also, he should check that the angle irons and the pedestal and vent-pipe holes are correctly located and oriented.
2. Following fixing of the two central slabs, mortar is applied to the exposed ringbeam to raise it to the level of the underside of the central slabs. This mortar should be smooth-finished, preferably with a steel trowel, and allowed to set for 24 hours.
3. A single strip of non-setting rubberized sealing compound is applied to one edge of all remaining joints between the six outer slabs and the inner slabs or ringbeam (this prevents the movement of insects to and from the pit and makes it airtight and odour-free). The outer slabs are then placed in position and butted tightly together.

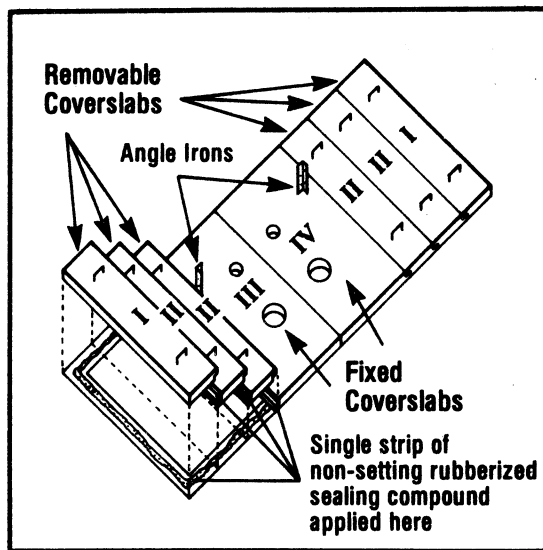

Laying the Coverslabs

Step 7: Backfill

Once the slabs are in place, the contractor may commence to backfill. In inspecting this operation, the TA must ensure that:

1. Backfill is properly completed.
2. Backfill is sloped away from the upper edge of the outer slabs to carry rainwater away from the latrine.
3. In order to prevent damage by rainwater, about 100 mm of the top surface of the backfill is composed of cement-stabilized material mixed in the proportion of 1 cement to 10 sand or soil.

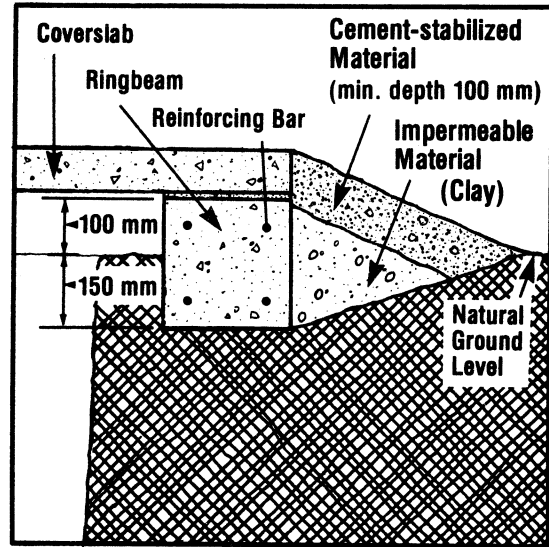

Backfill at Ringbeam

4. Inspecting and Assisting in the Construction of the Superstructure

This section presents an outline of the roles and responsibilities of the SHHA Technical Assistant (TA) in assisting plot-holders, or small contractors hired by plot-holders, to build an enclosed superstructure. The plot-holder must complete the superstructure within three months of being allocated the plot or else run the risk of forfeiting his Certificate of Rights.² Thus, the TA must do his utmost to ensure that the superstructure is completed on schedule. Regular visits should be made to the plot during the construction period and progress recorded on Latrine Inspection Record Sheets (see Appendix VII), to be supplied by individual SHHAs.

It is very important to inform plot-holders that they are permitted to use a wide variety of building materials in constructing the superstructure so that latrine completion need not be delayed by lack of funds. However, the superstructure must be properly enclosed, ventilated and roofed. It is also important to ensure that the ventpipes and flyscreens are delivered to the site by the SHHA Ward Office before construction begins, so that they may be properly incorporated. Latrine pedestals and a cap for the unused hole should be delivered to the plot-holder after his superstructure has been completed. Finally, the plot-holder should try to purchase or borrow all the materials he needs before construction begins so that he will not be delayed.

Two popular designs for a superstructure follow.

² The Certificate of Rights, as defined in Botswana, gives the grantee the right of occupancy of his plot in perpetuity, provided he constructs a latrine superstructure and a habitable room within a set time period, and maintains payment of a monthly service charge. This right of occupancy may be inherited or transferred.

4A. Concrete Block Superstructure

Stage 1: Framing

Having assembled the necessary tools and materials, the plot-holder can commence construction by setting out the first course of block loosely. The two angle irons which protrude from the central slabs establish the dimensions of the superstructure. They are located at the two outside rear corners of the superstructure. The door frame and ventpipes should also be raised and fixed. Flyscreens must be attached to the ventpipes before they are raised.

In inspecting this stage of construction, the TA should ensure that:

1. The minimum number of blocks is being used, in order to save money.
2. The walls are squared and properly located inside the angle irons.
3. The door frame and ventpipes are level, plumb, properly braced and located.
4. The door opens outwards so that there will be room inside the superstructure for the pedestal.
5. The ventpipes are long enough to extend at least 500 mm above the highest point of the roof, in order to ensure proper air flow.
6. Flyscreens are secured to the ventpipes by galvanized wire.

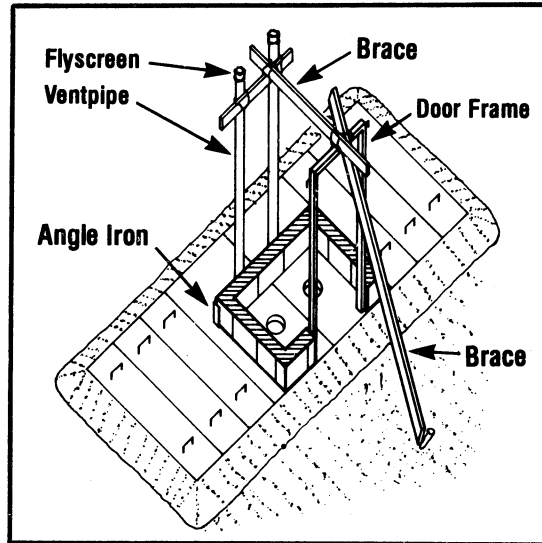

Framing the Superstructure

Stage 2: Blockwork

Following inspection of Stage 1 by the TA, the plot-holder may commence to construct the walls of the superstructure by laying the first course of blocks. The front wall should be at least nine courses high and the rear wall eight courses. A gap of 250 mm by 115 mm may be left in the seventh course of the rear wall for ventilation. If the interior of the house is too well lit, insects will be encouraged to enter or leave the pit through the pedestal instead of the ventpipes and they will thus be able to survive and breed.

In inspecting this stage of construction, the TA must ensure that:

1. Blocks being used are of reasonable quality, especially if made on the plot.
2. A damp-proof course is placed between the slab and the first course.
3. "Brick-force" or similar mesh reinforcement is placed at every second course.
4. Blockwork is plumb, square and level.
5. The ventpipes are secured to the second and sixth courses using galvanized wire or pipe clamps.
6. Mortar is mixed in the proportion of 1 cement to 6 sand.
7. Exterior walls are plastered.

Note that some plot-holders may wish to build privacy walls in front of their superstructures during this stage.

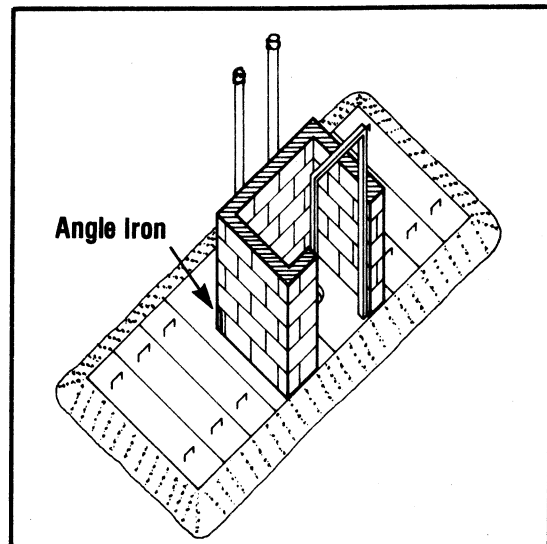

Constructing the Superstructure Walls

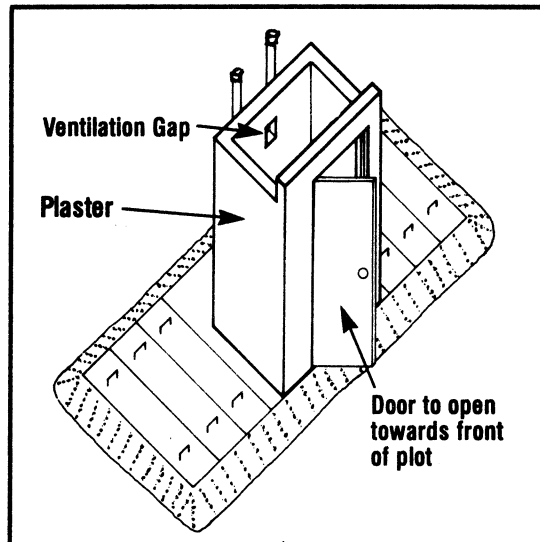

Completing the Superstructure Walls

Stage 3: Roof

Following inspection of Stage 2 by the TA, the plot-holder may commence to build the roof of the superstructure. This may be composed of 1500 mm long by 1700 mm wide asbestos or corrugated iron sheets. These must be cut to accommodate the ventpipes and secured to two 100 mm by 50 mm pine wall plates which are wired through the top two courses on the rear and front walls.

In inspecting this stage, the TA must ensure that:

1. The pine wall plates are properly secured to the top of the walls.
2. The roof sheets are properly secured to the rafters.
3. The ventpipes are well fixed and the flyscreens are not damaged.
4. The ventpipes extend at least 500 mm above the highest point of the roof.

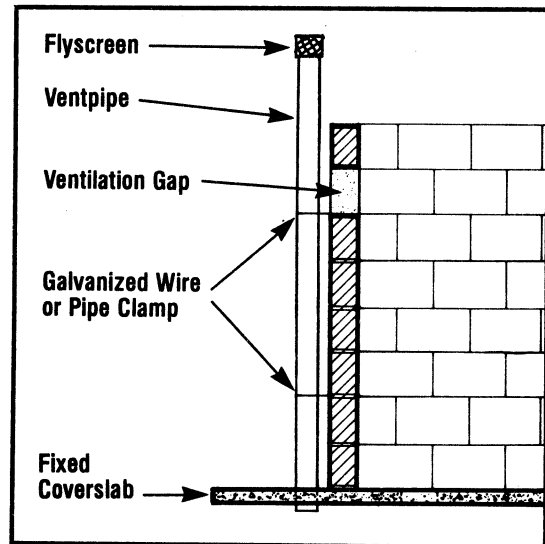

Section through Rear Wall

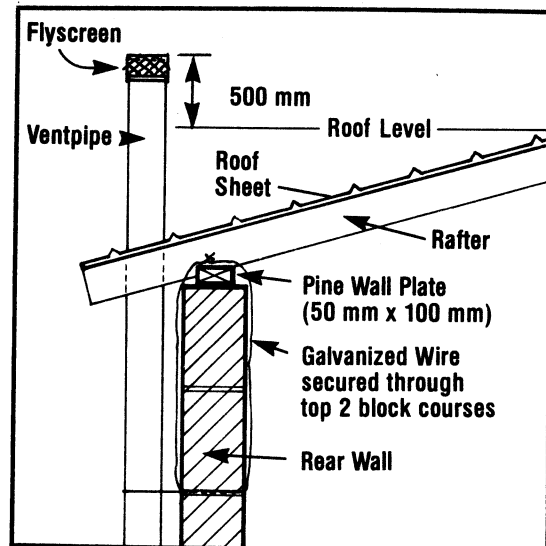

Roof Detail

Stage 4: Latrine Pedestal and Cap

The latrine is completed by securely fixing the latrine pedestal and concrete cap so that they are air-tight. This ensures that smells and flies do not enter the superstructure.

4B. Alternative Superstructure

A less expensive, but equally acceptable, superstructure may be constructed using local materials, as follows:

Stage 1: Framing

1. Wire two rear gumpoles to the angle irons protruding from the central slabs.
2. Secure two front gumpoles to front face of substructure ensuring that they are slightly taller so that roof will drain.
3. Frame side and rear walls at upper, middle and lower positions with wood purlins.
4. Continue upper frame over front wall and add second upper purlin.
5. Secure wooden door frame to front gumpoles, ensuring that door will open outwards.
6. All work should be plumb and square.

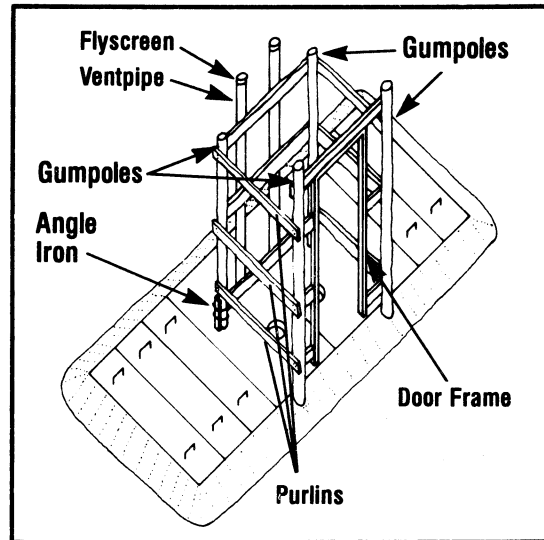

Framing the Superstructure

Stage 2: Walls

1. Stretch continuous chicken wire over side and rear walls and secure to gumpoles and purlin frame. Leave ventilation space at top.
2. Stretch cured hessian cloth (burlap) over chicken wire frame and secure. To cure the hessian, it should be dipped in a salt/cement/warm water bath (6 kg salt to 50 kg cement to 70 litres water). Cured hessian should be allowed to dry on the frame for at least 2 days.
3. Wire flyscreens to ventpipes, raise and secure to wooden frame using galvanized wire. Ensure that the ventpipes are long enough to extend at least 500 mm above the highest point of the roof, in order to ensure proper air flow.
4. Apply one coat wet cement mortar mixture (1 cement to 6 sand), using large plastering brush, to exterior side of hessian frame and let dry. Repeat for second coat.
5. Walls should be kept moist for at least 3 days in order to cure properly.

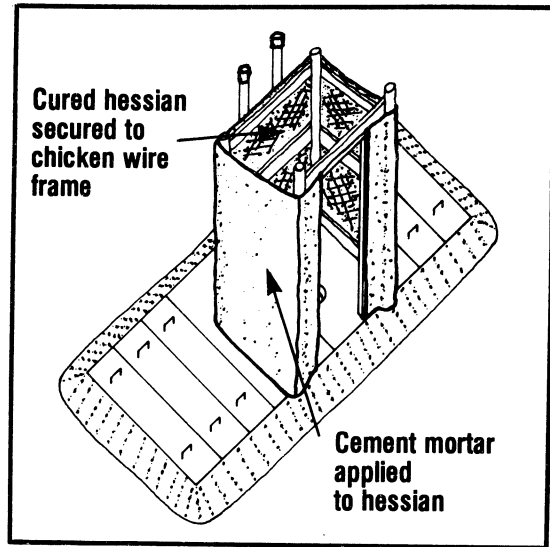

Constructing the Superstructure Walls

Stage 3: Roof and Door

1. Secure tin or corrugated iron roof to gumpole frame, ensuring that appropriate holes are cut to accommodate the ventpipes.
2. Secure door to door frame, ensuring that it opens outwards.

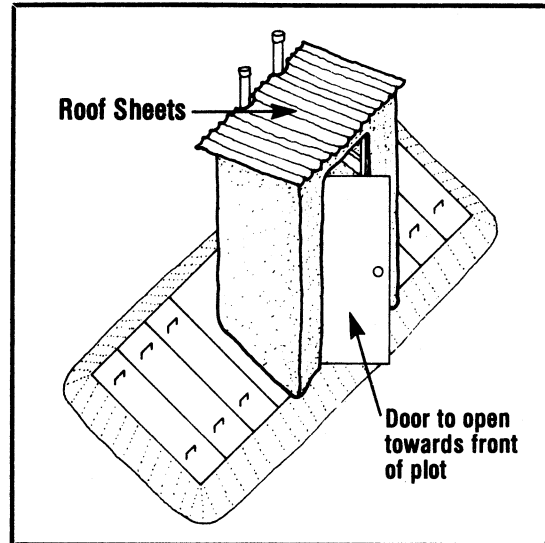

Completing the Superstructure

5. Monitoring the Ventilated Improved Double-Pit (VIDP) Latrine

The SHHA Technical Assistant (TA) shares the responsibility for monitoring the regular use of the REC II latrine with plot-holders, SHHA Group Workers and local Council health staff. However, because he is likely to have particularly close contact with individual plot-holders, he should be fully informed on what to look for and what advice to give.

At the completion of the construction of the superstructure, the TA should review the following principles of operation of the latrine (also illustrated on the REC II Operations Sheet) with the plot-holder. In turn, these should be monitored in the months and years ahead in order to ensure proper use, and longer life, of the latrine.

1. Minimize input of water into the pits

The REC II is a dry latrine. Urine and small amounts of water entering the pit will eventually evaporate or soak into the soil. However, excessive amounts of water from bathing or cooking must not be emptied into the pits. This water would accumulate and harbour breeding insects.

Bathing water or dishwater should be emptied into a drainage ditch adjacent to the plot or, where available, into a soakaway located elsewhere on the plot.

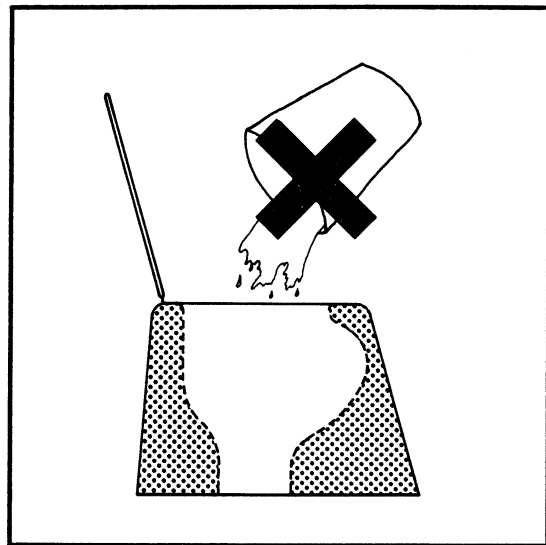

2. Do not put rubbish into the pits

Tins, bottles, vegetable matter or other sorts of refuse must not be placed in the pit. These materials may block the hose on the suction tanker truck when they are removed later. All refuse must be placed in the rubbish bins provided by SHHA.

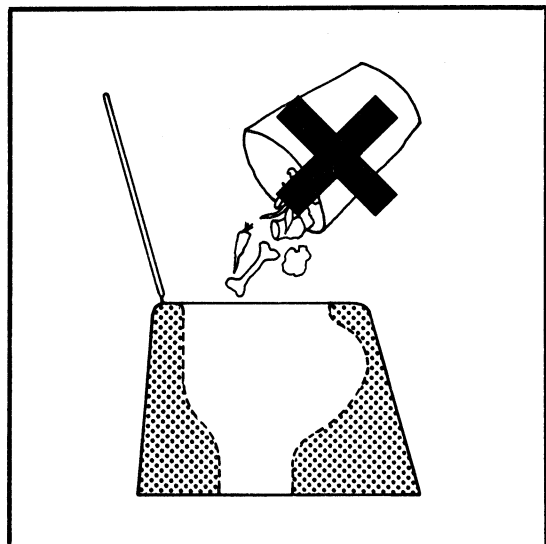

3. When a pit is full, notify the SHHA office immediately

When one pit fills, the plot-holder must move the pedestal to the other pit, recap the first, and notify the SHHA Ward Office immediately.

The TA should inspect the first pit to make sure it is full and record the plot-number and date for future reference. Council should then be notified to empty the pit after a minimum period of one year or when the second pit is half full. This allows time for material in the full pit to dry out and decompose. After the pit has been emptied, the TA must ensure that Council replaces the strip of non-setting rubberized sealing compound before resetting the slabs.

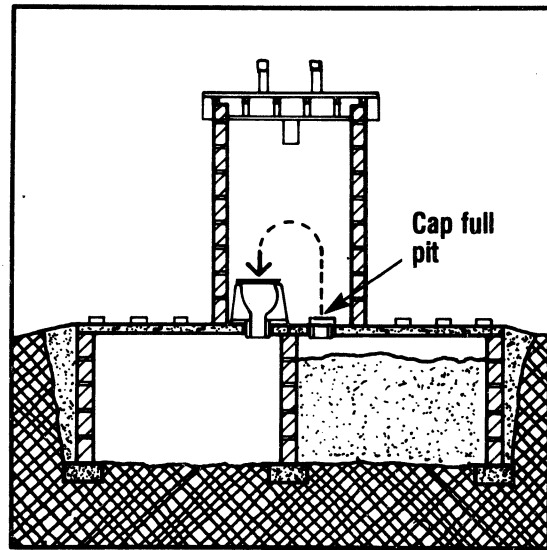

4. Do not use both pits at the same time

The two pits must not be used at the same time. If they are, the toilet cannot be maintained and it will fail.

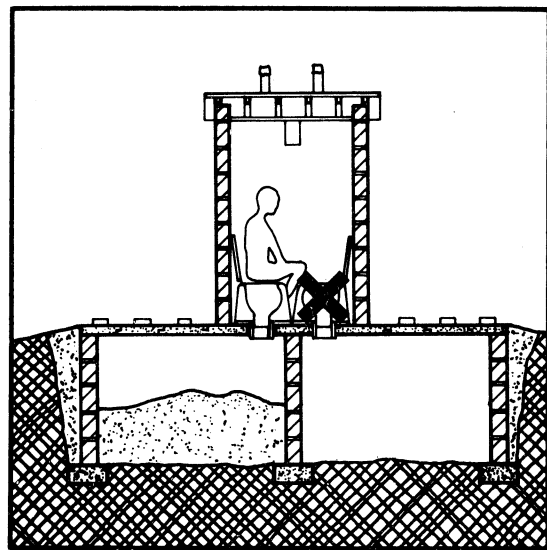

5. Keep the pedestal seat cover closed

When not in use, the pedestal seat cover should be kept closed. This will discourage insects from entering the pit and will keep the pit dark. Thus, insects will be forced to travel up the ventpipes towards light and will be trapped by the flyscreen. Air will continue to enter the pit through the gap under the seat, maintaining the ventilation of the pit.

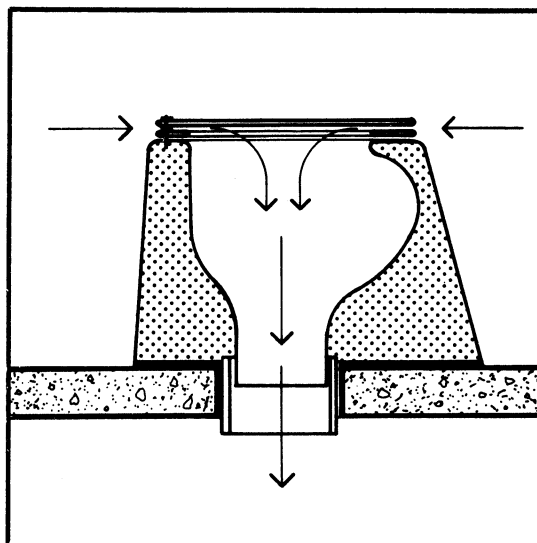

6. Inspect the flyscreens and coverslabs regularly

The flyscreens at the top of the ventpipes and the coverslabs over the pit should be inspected every 6 months to ensure that they are properly secured and in good condition. Flyscreens should be made of plastic-coated glass-fibre mesh only. If the ventpipes or coverslabs need repair, report this to the SHHA Ward Office.

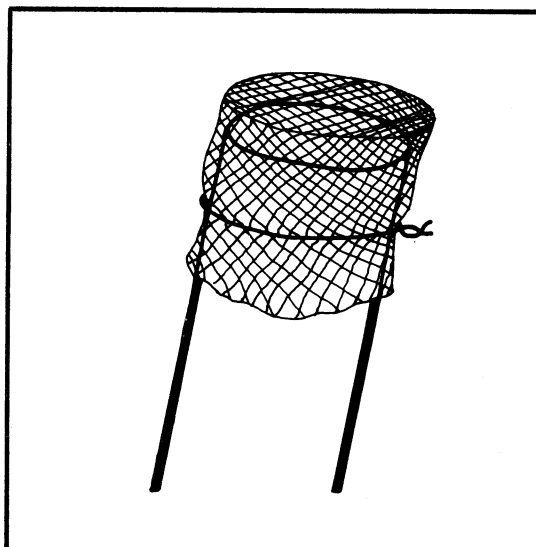

7. Keep the superstructure clean

The inside of the superstructure and the pedestal should be kept clean so as not to attract insects or create foul smells. The door should be kept closed when the latrine is not in use.

A small amount of water may be used to clean the inside of the pedestal.

8. Ensure that the entire family uses the latrine

Ensure that every member of the plot-holder's family, especially small children and elderly people, use the latrine rather than the adjacent grounds. Children's waste found outside the latrine should be dropped through the latrine pedestal into the pit.

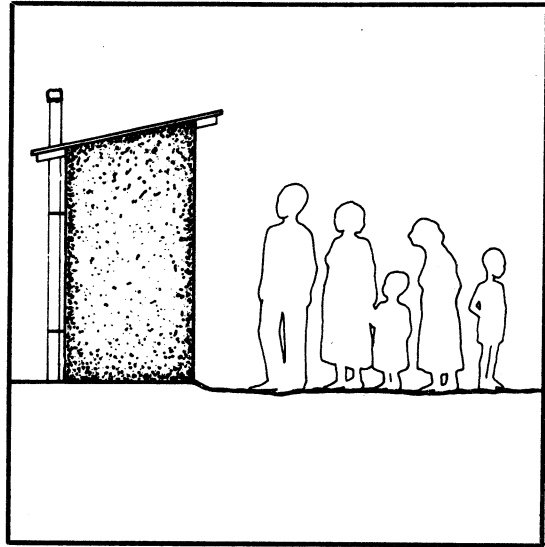

9. Ensure that the REC II Operations Sheet is pinned inside the latrine

REC II Operations Sheets should be distributed by SHHA to all plot-holders. The TAs should check periodically to ensure that this sheet is displayed prominently inside the latrine.

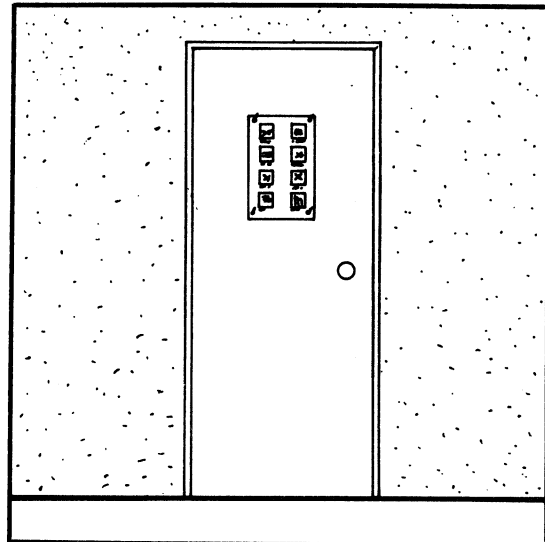

Appendix I

Substructure in Unstable Soils: List of Materials

Item	Description (see also Appendix III)	Quantity
1.0	Excavation of pit complete, including any necessary shoring of sides, keeping free of water. Item measured net, to include for any necessary over-excavation	12.0 m ³
2.0	Concrete (class 1:2:4) in foundations, including all necessary formwork, etc.	1.0 m ³
3.0	Blockwork, including all necessary backfill in cement-stabilized material	16.0 m ²
4.0	Precast coverslabs (see Appendix V)	
	Slab I	2
	Slab II	4
	Slab III	1
	Slab IV	1
5.0	Concrete cap	1
6.0	Non-setting rubberized sealing compound	

Appendix II
Concrete Block Superstructure: List of Materials

Item	Description (see also Appendix VI)	Quantity
1.0	Pressed metal door frame for 115 block wall complete with pressed metal door (Left-hand door - open out - with mortice lock - door 813W c 2032H) Alternative - with external quality timber door	1
2.0	PVC ventpipes, 110 mm dia., 2.5 m long	2
3.0	Plastic-coated glass-fibre mesh pieces 300 mm square, plus fixing wire	2
4.0	115 mm blocks	90-100
5.0	10-gauge galvanized wire pieces 1 m long (4 for roof, 3 for each ventpipe)	10
6.0	Pine wall plate, 100 x 50 x 1700 mm long	2
7.0	Roof rafters (optional)	4
8.0	Roof sheeting, 1500 mm long x 1700 mm wide, including roofing screws, cut for ventpipes as shown	1
9.0	Latrine pedestal	1
10.0	Cement - 50 kg packet	1
11.0	Pit sand (wheelbarrows)	1-2
12.0	Emulsion paint to bagwash for walls	2.00 litres
13.0	Gloss paint for door and frame (optional)	0.25 litres

Appendix III
Substructure in Unstable Soils: Plans

Foundation Plan

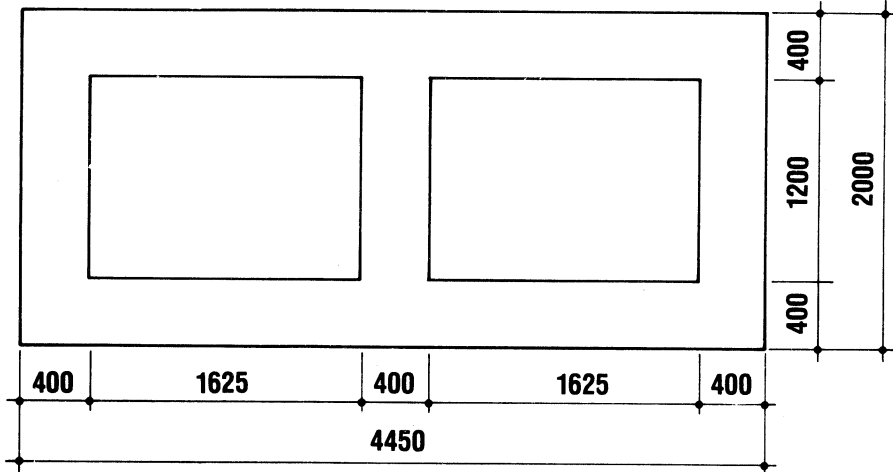

Unreinforced concrete strip foundation to be 200 mm thick. Top of footing to be 1250 mm below natural ground level. Concrete to be mixed at 1:2:4.

Plan of Coverslabs

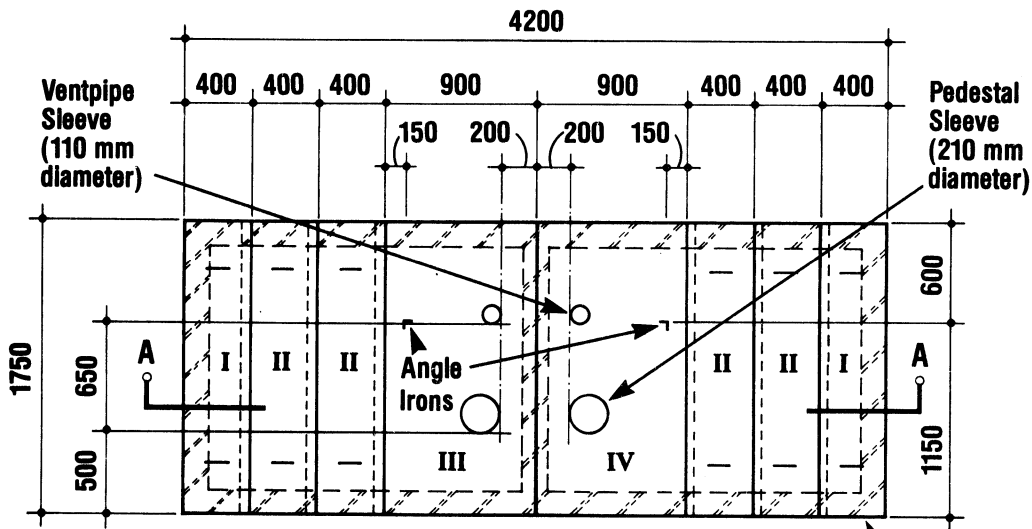

All holes to be formed with prefabricated pvc sleeves (sizes shown are internal diameters with sleeves removed)

Concrete Block Walls (under)

All dimensions are in millimetres



Drawn by
 Ministry of Local Government
 and Lands,
 Government of Botswana

**Appendix III
Substructure in Unstable Soils: Section**

Section A-A

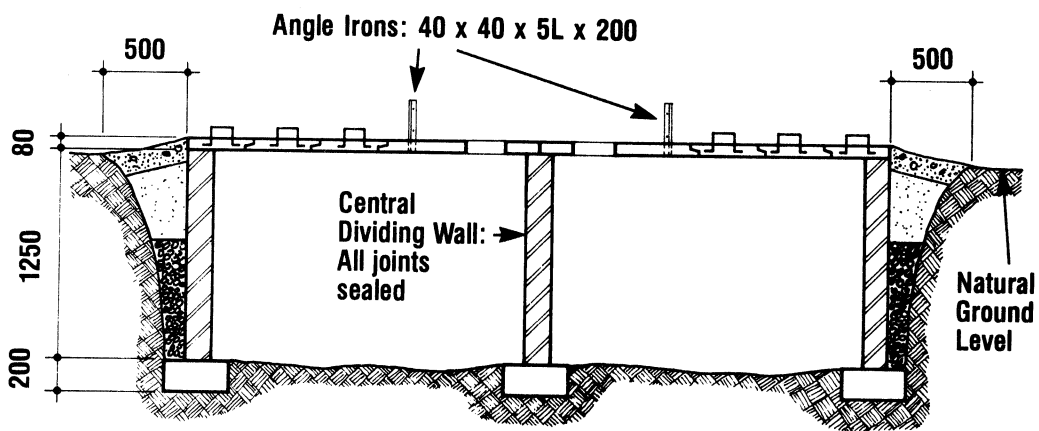

Perimeter wall to be 5 courses 150 mm solid concrete block. All joints in top 2 courses to be sealed. All other vertical joints to be open to 10 mm width. Mortar mix to be 1:4.

All dimensions are in millimetres



Drawn by
Ministry of Local Government
and Lands,
Government of Botswana

Appendix IV
Substructure in Stable Soils: Plan and Section

Plan of Ringbeam

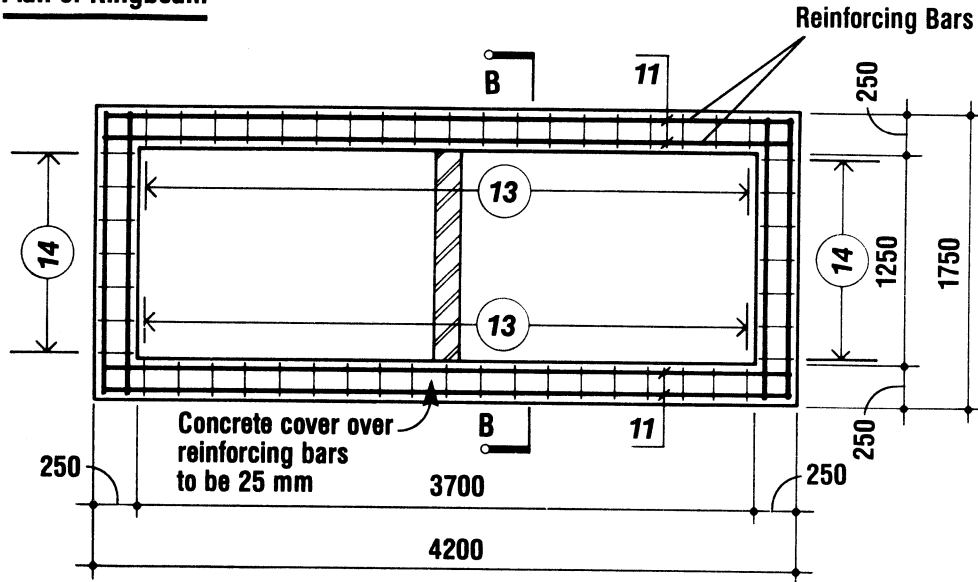

Central dividing wall to be 150 mm solid concrete block. All joints to be sealed. Top of wall to be flush with underside of ringbeam. All mortar to be mixed at 1:4. Concrete cover over reinforcement bars to be 25 mm.

Section B-B

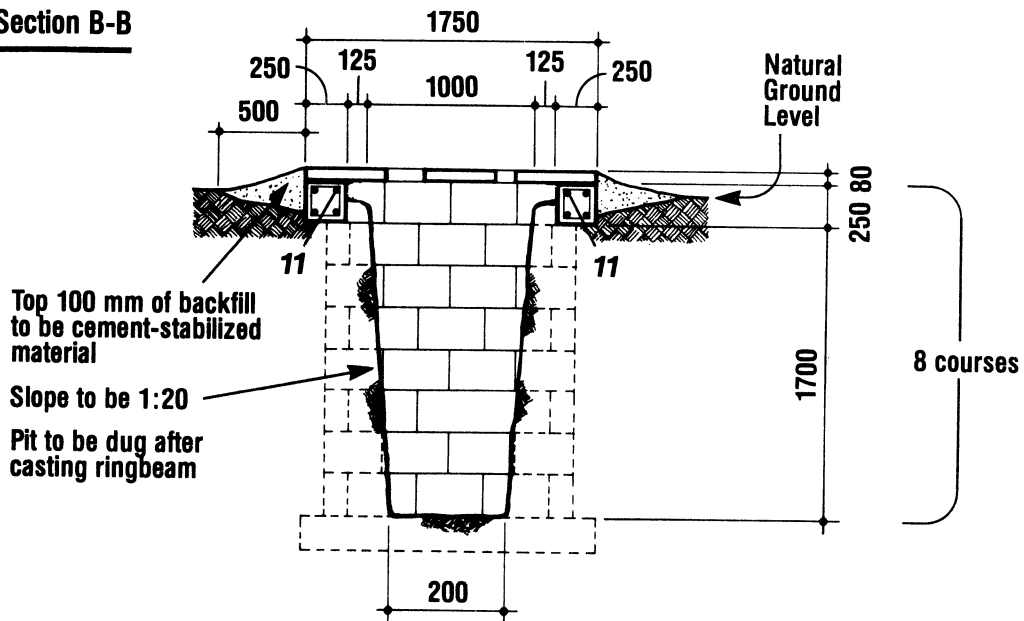

All dimensions are in millimetres



Drawn by
 Ministry of Local Government
 and Lands,
 Government of Botswana

Appendix V
Coverslabs/Types I & II: Plans and Sections

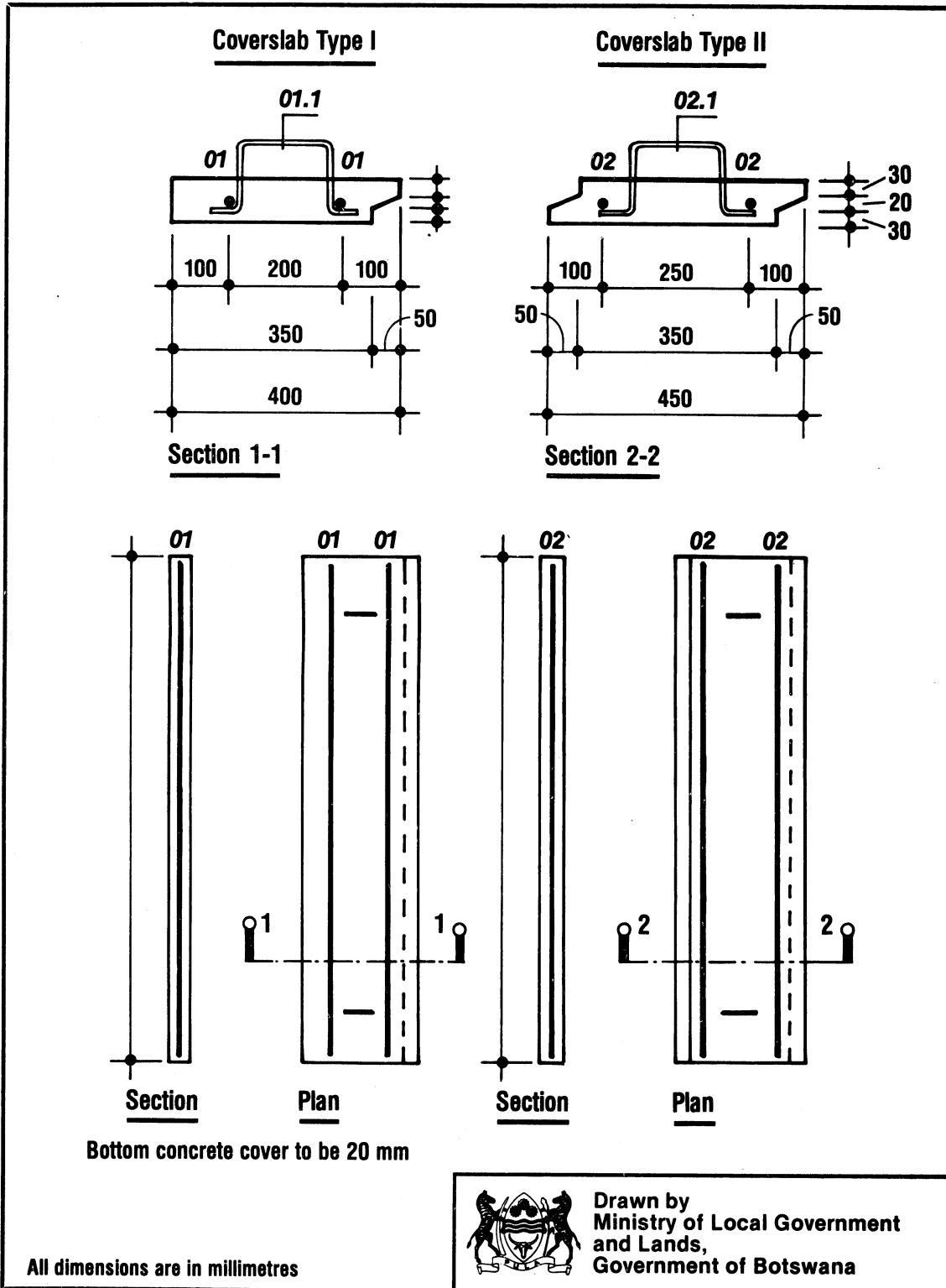

Appendix V
Coverslabs/Type III: Plan and Sections

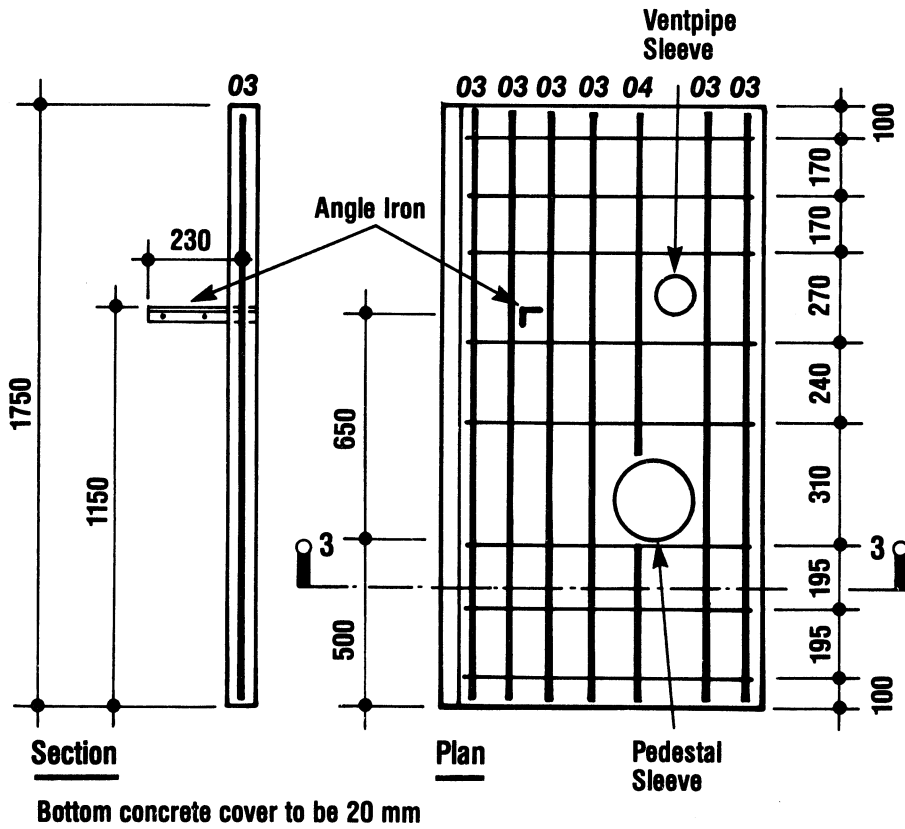
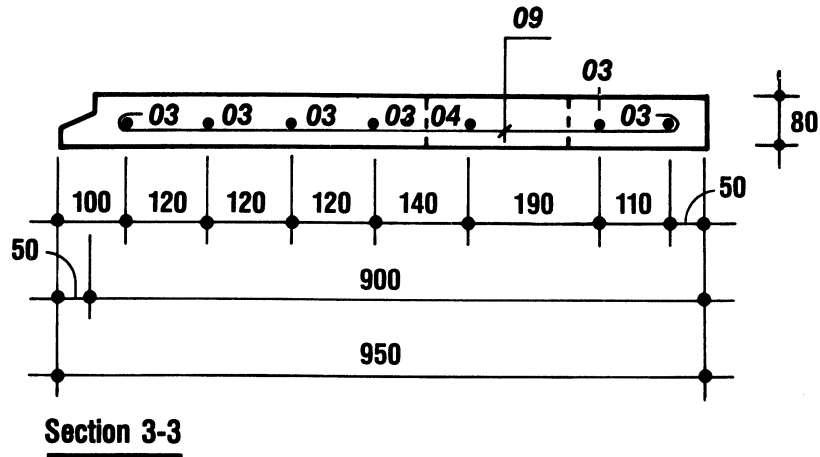

All dimensions are in millimetres



Drawn by
 Ministry of Local Government
 and Lands,
 Government of Botswana

Appendix V
Coverslabs/Type IV: Plan and Sections

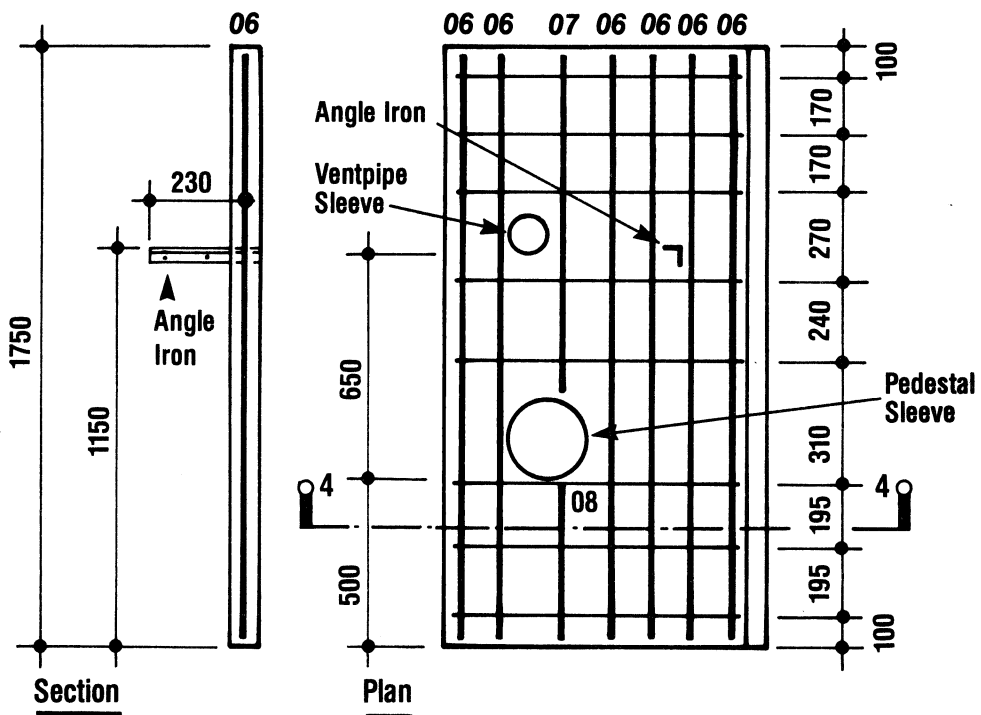
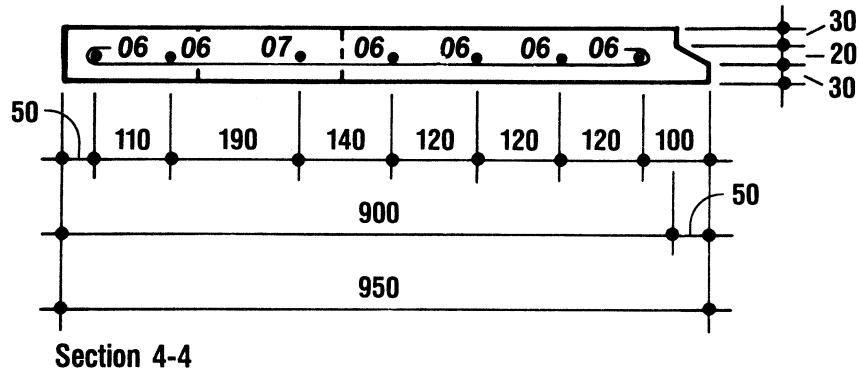

Bottom concrete cover to be 20 mm

All dimensions are in millimetres



Drawn by
 Ministry of Local Government
 and Lands,
 Government of Botswana

Appendix V
Coverslabs: Bending Schedule Concrete Cap: Plan and Section

Bending Schedule									
Component Location	No. Off	Label	No. Placing & Fixing	Layer	No. in Each	Type, Size Mark	Total no.	Length mm	Shape Code
SLAB I	2	01	2 AS SHOWN	B	2	Y1201	4	1700	20
		011	2 AS SHOWN		2	R08011	4	520	83
SLAB II	4	02	2 AS SHOWN	B	2	Y1202	8	1700	20
		021	2 AS SHOWN		2	R08021	8	520	83
SLAB III	1	03	6 AS SHOWN	B	6	Y1203	6	1700	20
		04	1 AS SHOWN	B	1	Y1204	1	1000	20
		05	1 AS SHOWN	B	1	Y1205	1	450	20
SLAB IV	1	09	8 AS SHOWN	B	8	R0609	8	1000	33
		06	6 AS SHOWN	B	6	Y1206	6	1700	20
		07	1 AS SHOWN	B	1	Y1207	1	1000	20
		08	1 AS SHOWN	B	1	Y1208	1	450	20
		10	8 AS SHOWN	B	8	R0610	8	1000	33

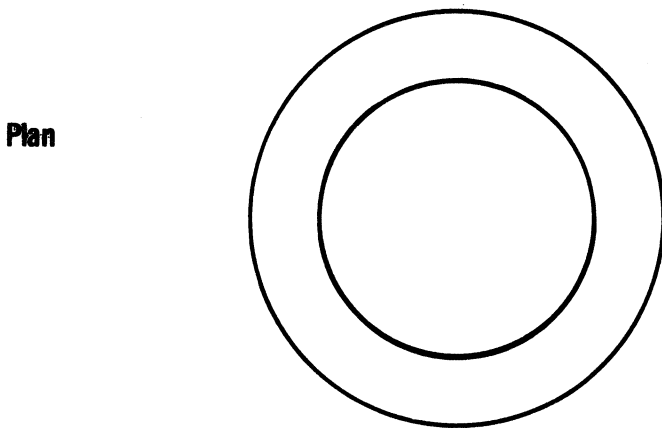
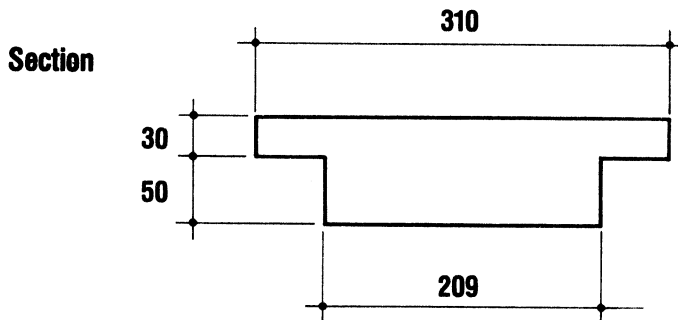

All dimensions are in millimetres



Drawn by
 Ministry of Local Government
 and Lands,
 Government of Botswana

Appendix VI
Concrete Block Superstructure: Plans

Roof Plan

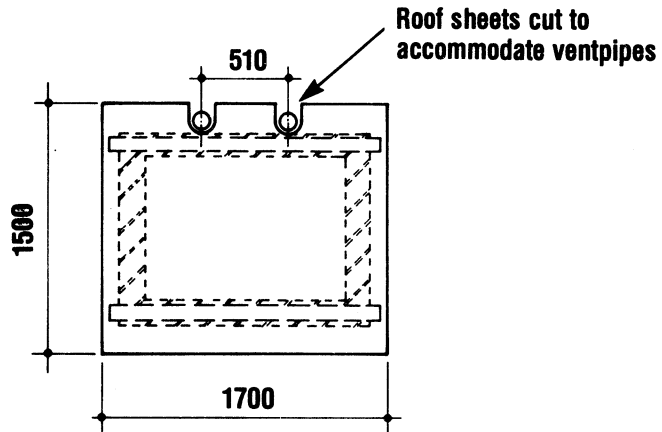

Floor Plan

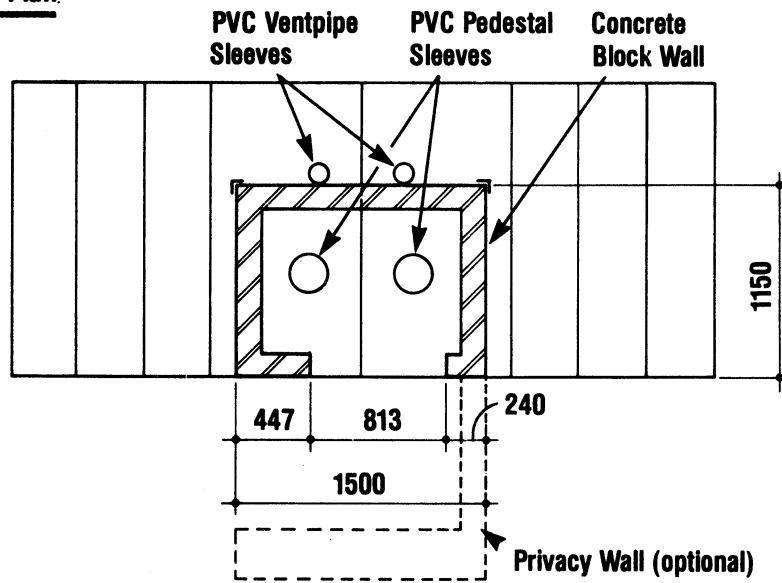

All dimensions are in millimetres



Drawn by
 Ministry of Local Government
 and Lands,
 Government of Botswana

Appendix VI
Concrete Block Superstructure: Front Elevation

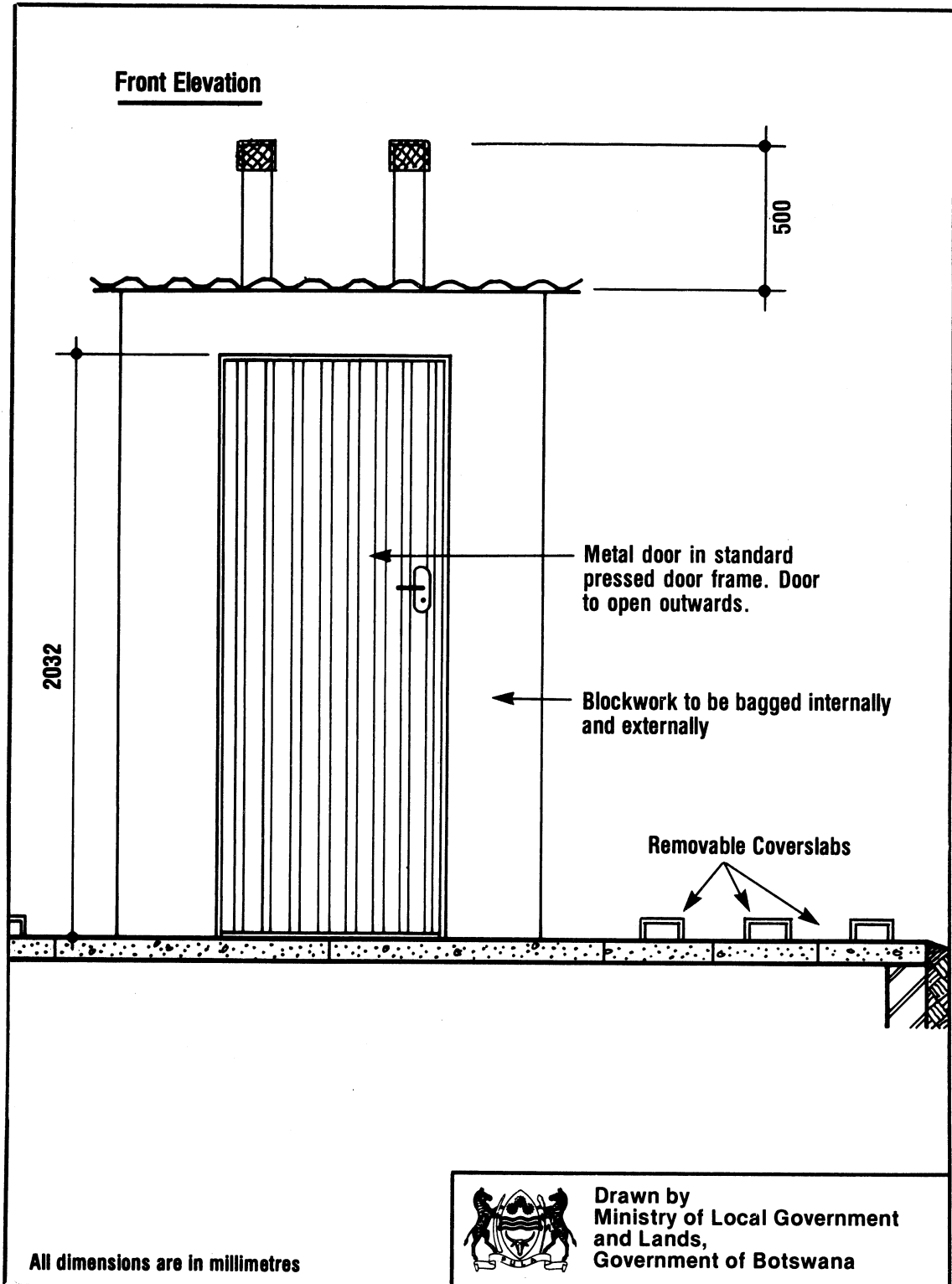

**Appendix VI
Concrete Block Superstructure: Section**

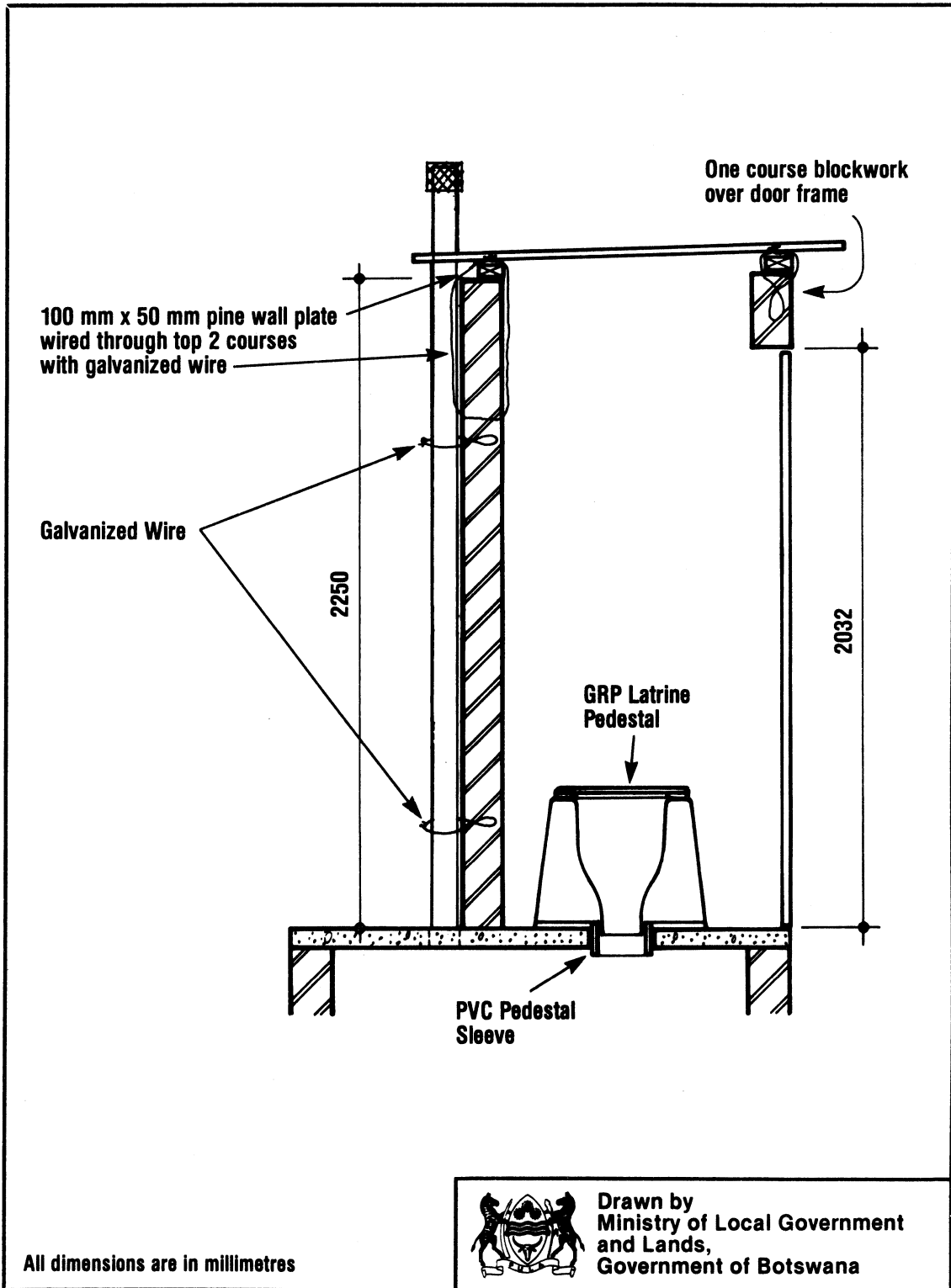

Appendix VII
Latrine Inspection Record Sheet

Note: The Senior Technical Officer (or Senior Works Foreman) for each SHHA District should prepare a standard Latrine Inspection Record Sheet for use by the SHHA Technical Assistants. This sample is provided for reference purposes only, and should be amended or improved as each Senior Technical Officer sees fit. One clean copy of the Latrine Inspection Record Sheet for each SHHA plot should be filed permanently at SHHA headquarters.

Name of SHHA Housing Area: _____

Plot Number: _____

Name of Plot-Holder: _____

Name of SHHA Technical Assistant: _____

1. Inspection of Substructure Built in Unstable Soil

	Date	Time	Signature
A. Staking Completed			
B. Latrine Correctly Oriented/Located			
C. Hand Augering Completed			
D. Excavation Completed			
E. Foundation Completed			
F. Coverslabs Delivered Intact			
G. Coverslabs Installed			
H. Backfill Completed			
I. Site Grading/Clean-up Completed			

Substructure Completed Date: _____

Signature of SHHA Senior Technical Officer
 or Senior Works Foreman: _____

2. Inspection of Substructure Built in Stable Soil

	Date	Time	Signature
A. Staking Completed			
B. Latrine Correctly Oriented/Located			
C. Hand Augering Completed			
D. Ringbeam Completed			
E. Excavation Completed			
F. Dividing Wall Completed			
G. Coverslabs Delivered Intact			
H. Coverslabs Installed			
I. Backfill Completed			
J. Site Grading/Clean-up Completed			

Substructure Completed Date: _____

Signature of SHHA Senior Technical Officer

or Senior Works Foreman: _____

3. Inspection of Superstructure

	Date	Time	Signature
A. Orientation Correct			
B. Location on Coverslabs Correct			
C. Blockwork Completed			
D. Ventilation Gap Completed			
E. Door Correctly Installed			
F. Ventpipes Secured to Rear Wall			
G. Flyscreens Installed			
H. Roof Complete			
I. Latrine Pedestal/Concrete Cap Delivered			

Superstructure Completed Date: _____

Signature of SHHA Senior Technical Officer

or Senior Works Foreman: _____

4. Operations Inspection

	Yes	No
A. Is there any water or rubbish in the pit?	<input type="checkbox"/>	<input type="checkbox"/>
B. Is only one pit being used?	<input type="checkbox"/>	<input type="checkbox"/>
C. Is the unused pit correctly capped?	<input type="checkbox"/>	<input type="checkbox"/>
D. Are the superstructure and latrine pedestal clean?	<input type="checkbox"/>	<input type="checkbox"/>
E. Is the pedestal seat cover closed?	<input type="checkbox"/>	<input type="checkbox"/>
F. Are both flyscreens intact?	<input type="checkbox"/>	<input type="checkbox"/>
G. Are children using the latrine?	<input type="checkbox"/>	<input type="checkbox"/>
H. Is the operations sheet posted inside superstructure?	<input type="checkbox"/>	<input type="checkbox"/>

Comments and Recommendations:

Action Required by: _____

Date: _____

Signature of TA: _____