

Multi-Purpose Buildings for Disaster Situations in Thailand

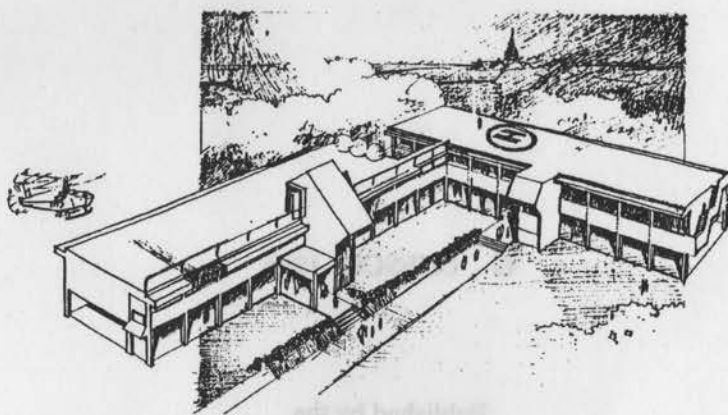

Report prepared by
Mr. Kriangsak Charanyanond, Architect

To cope with disaster situations caused by frequent floods and strong winds in the south of Thailand, a Task Force within the Thailand Department of General Education has analyzed the threats, developed maintenance procedures and proposed a prototype multi-purpose building for primary and secondary schools. They have recommended the construction of this building as a pilot project that will be analyzed and evaluated prior to its replication nationwide.

This Report has been designed as a technical reference for educational planners, administrators, facilities specialists and educators at the school level.



Multi-Purpose Buildings for Disaster Situations in Thailand

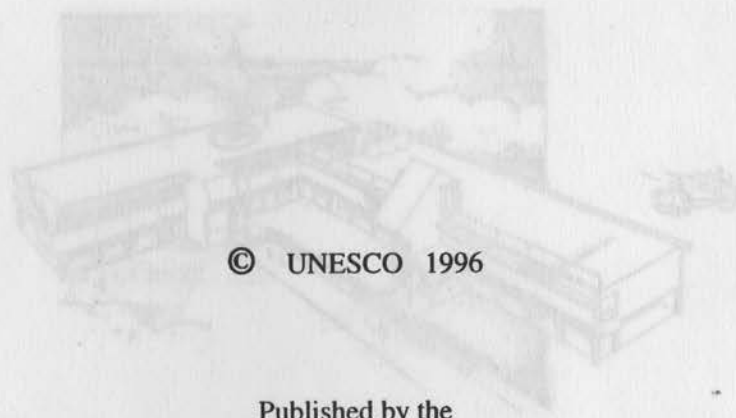

© UNESCO 1996

Published by the
UNESCO Principal Regional Office for Asia and the Pacific
P.O. Box 967, Prakanong Post Office
Bangkok 10110, Thailand

Printed in Thailand

The designations employed and the presentation of material throughout the publication do not imply the expression of any opinion whatsoever on the part of UNESCO concerning the legal status of any country, territory, city or area or of its authorities, or concerning its frontiers or boundaries.



CONTENTS

Acknowledgement	i
Preface	iii
Chapter One : Introduction	1
Chapter Two : Nature of wind and flood threats in Thailand	3
Chapter Three : Description of the problems	7
Chapter Four : Recommendations for post-flood maintenance	12
Chapter Five : Considerations for the design of typhoon-resistant buildings	17
Chapter Six : Designing for wind loads	22
Chapter Seven : Prototype design	32
Chapter Eight : Recommendations and applications	42
Bibliography	45
ANNEXES	
Annex I	49
Annex II	50

ACKNOWLEDGEMENT

The Department of General Education expresses its gratitude to UNESCO for financial and technical support to this project. Special thanks go to Mr. John Beynon, Principal Architect, UNESCO, for the dedication and moral support which he provided to the Task Force by supplying references for the study. His help greatly facilitated the work of the Task Force and brought about concrete success to the project, thus benefiting further studies in this area.

PREFACE

For the past few years, the south of Thailand has experienced frequent floods and strong winds that have disrupted school operations. Typhoon Gay, which had a velocity exceeding 120 km. per hour near the centre, hit Chumphon in 1989 causing major damage to many public buildings in the area.

The architect of the Department of General Education studied the report of engineers who investigated the affected areas and consulted with UNESCO experts. The consultation concluded with an agreement for UNESCO to provide financial and technical assistance to a study undertaken in 1991 leading to the development of a prototype multi-purpose building suitable for small primary and secondary schools in rural areas in the South.

The Task Force, which was formed to undertake the study, began its work by surveying construction sites in Chumphon, Surat Thani and Nakhon Sri Thammarat to study the geographic characteristics of these areas. It studied the approaches and techniques used by other government agencies, such as the Army Weaponry Department and the Department of Civil Works, in building dams and repairing public and private buildings. The building structures and construction methods for these areas as used by these departments were analyzed.

In addition, the Task Force interviewed the staff of the Meteorological Department to obtain information on disasters caused by tropical depressions and the amount of rain in the affected areas, with a view to comparing such information with UNESCO-supplied data on the approaches adopted by other countries that are similarly located in cyclone zones. This generated more thorough information for the report.

Special thanks go to the members of the engineering team who developed the prototype building during the final phase of the study and studied the wind force acting upon various parts of the building, strengthening its framework so that it can resist strong winds and serve as a safe shelter for the students during cyclones and prolonged torrential rains.

The Department of General Education is grateful to the members of the Task Force for taking time off from their regular work and dedicating themselves to this study.

Chapter One

INTRODUCTION

For the past few years, the Department of General Education (DGE) has been supporting the restoration and maintenance of school buildings in many flash flood and typhoon-prone provinces in the central and southern regions of Thailand.

A major problem is that the design of most classrooms and auxiliary buildings in the area is suited for normal conditions, that is, the building foundations, as stipulated by municipal laws, can only withstand specific typhoon conditions. However, these limits vary according to the height of buildings. Although certain assumptions are made (e.g. the unlikelihood of flooding in elevated areas and the availability of standard materials), there are no stringent specifications to ensure resistance against heavy storms and floods. For these reasons, many schools are seriously affected by these natural disasters.

There is a need to study the functional aspects of classroom and auxiliary buildings for primary grades upwards, with a view to developing specifications that would ensure efficient building use and strength to cope with typhoons and floods. As the Meteorological Department is now capable of forecasting typhoons, this is an opportune time for serious studies on the subject.

Although the design specifications for buildings in typhoon-affected areas are still under development, architects and engineers have enough data on hand to be able to design strong buildings. Taking into account the fact that very strong typhoons occur only once every 25 years or so, building designers have enough time to update basic design theories so that they respond to emerging needs and trends. Municipal regulations should stipulate new standards that would take these needs and trends into account.

Typhoon Gay hit Chumphon province on 3 November 1989, travelling at a speed of 120 km. per hour near the centre. It was the strongest typhoon to hit the area in 35 years. Another typhoon of almost the same speed occurred in the nearby province of Nakhon Sri Thammarat.

Schools in Thasae district, Chumphon, were reconstructed and fortified with stronger structures, especially the rooves. However, as the information on which the fortifications were based was gathered within a very short period of time, they did not provide a sufficient basis for the development of a building design that can cope with strong typhoons and provide an immediate, safe shelter for students in emergency cases.

This report begins with an examination of climates that are conducive to typhoons and floods in certain zones, followed by a presentation of survey data from certain parts in the central and southern regions, flood preparation measures, and requirements for the design of buildings in typhoon zones.

On the basis of the above information, the report delineates a set of design criteria as a general guideline for the design of a prototype school building. It then presents a prototype low-cost, multi-purpose building that meets the stated requirements.

The report proposes a set of recommendations, including construction of a single building as a pilot project. The building's utilization is studied and the findings are used to modify the prototype for mass replication.

The DGE received financial and technical assistance from UNESCO to conduct this study. Acting as liaison, UNESCO invited documents from Sri Lanka, Bangladesh and the Philippines, each of which is conducting studies of a similar nature. This facilitated access to comparative data from neighbouring countries.

The Task Force surveyed flooded areas in Surat Thani, Nakhon Sri Thammarat and Chumphon. Actual data was collected and buildings constructed in these areas by other agencies, such as the Army Weaponry Department and the Department of Civil Works, were studied with a view to generating new ideas for the development of a prototype building.

Chapter Two

NATURE OF WIND AND FLOOD THREATS IN THAILAND

Thailand is located in the tropical zone of Southeast Asia. The central part of the country is a low plain through which several rivers pass. The northern part is a mountainous highland. The country has a total land area of 513,115 sq. km.

Thailand stretches approximately 1,600 km. from north to south and has a width of about 800 km. from east to west at a latitude of 15 degrees north. Its coastline is 2,300 miles long, east to the Gulf of Thailand and west to the Andaman Sea. The northern border is surrounded by mountain ranges whereas the northeastern region is a highland.

Meteorologically speaking, Thailand is too small to be divided into several zones. It has a more or less uniform climate throughout the country. Taking into account slight differences, the country may be divided into five climatic areas as follows:

- 1. North Region.** The region consists of 15 provinces (see map) with a total area of approximately 153,000 sq. km. and an altitude of about 400 metres above sea level. It has mountain ranges in the northern border, with an altitude of about 1,600 metres above sea level. Mountain ranges and several rivers make it a fertile area in which a variety of trees grow in abundance.
- 2. Northeast Region.** The region consists of 17 provinces with a total land area of approximately 170,000 sq. km. and an altitude of about 250 metres above sea level. The region is a highland inclined to the southeast. To the east lie Petchaboon and Dong Phrayayen mountain ranges, which are between 800 and 1,300 metres above sea level. These mountain ranges divide the northeast, north and central regions. To the south lie Sankampaeng and Phanomdongrak mountain ranges that divide Thailand and Cambodia. The Phanomdongrak range is about 400 metres above sea level and acts as a shield against the southwestern wind from the Gulf of Thailand, thus hindering rainfall and making the area arid. It is rather cold in the cold season because of the effect of the high depression from the north and extremely hot in the hot season because of its distance from the sea.

3. **Central Region.** The region consists of 18 provinces with a total land area of approximately 73,000 sq. km. and an altitude of about 30 metres above sea level. The area is generally a low plain with some low mountain ranges. In the west close to the Burmese border lies the Tranaosri mountain range with an altitude of about 1,650 metres above sea level. Several rivers pass through this region to the Gulf of Thailand, such as the Chao Phraya, Thachin and Mekong Rivers. Hence, this region is vulnerable to flooding in the rainy season.
4. **East Region.** The region consists of seven provinces with a total land area of approximately 34,000 sq. km. It has an altitude of about 40 metres above sea level. To the east lies the Bantad mountain range that borders Cambodia. Lying next inside the region is the Chanthaburi mountain range. This region has an eastern coast that stretches over the Gulf of Thailand and experiences heavy rainfalls in the monsoon.
5. **South Region.** The region consists of 16 provinces with a total land area of approximately 33,000 sq. km. It has a distance of about 640 km. from north to south. Most of the area is forested and mountainous. The west coast is somewhat steeper than the east coast. On the Andaman Sea parallel to the coast lies the Tranaosri mountain range. The Phuket and Nakhon Sri Thammarat ranges lie north to south, joining the Kalagiri range in Malaysia. This region is subject to the monsoon from both the Pacific Ocean and the Andaman Sea, experiencing heavy rainfalls and excessive flooding in the rainy season.

Climate

Thailand is under the influence of two types of monsoon, namely the northeastern wind and the western wind.

The northeastern monsoon between May and October causes rainfalls and brings in moisture from the Indian Ocean to the whole country. In October the wind changes its direction and depressions come in from the South China Sea, passing through Southern Thailand towards the Gulf of Bengal. These depressions cause heavy rains and floods. Sometimes a depression may transform into a typhoon, causing heavy damage to certain areas in the south, particularly the eastern sea coast.

Floods and typhoons damage houses, shelters and public buildings, such as school buildings, health facilities, etc. This has prompted the Government to allocate annual contingency funds for the restoration and repair of damaged public buildings. Temporary classroom shortage, while the old structures are being restored or repaired or new ones are being constructed, could be a problem if it disrupts school operations and the students' grades fall below the norm.

Records of Rainfall for Southern Provinces

Selected Provinces	Prachuap	Chumphon	Surat	Nakorn Sri Thammarat	Songkhla
November 1988 Rainfall (M.M.)	400	800	1,500	1,600	1,000
Annual Rainfall (M.M.)	1,800	2,079	2,028	2,478	2,153

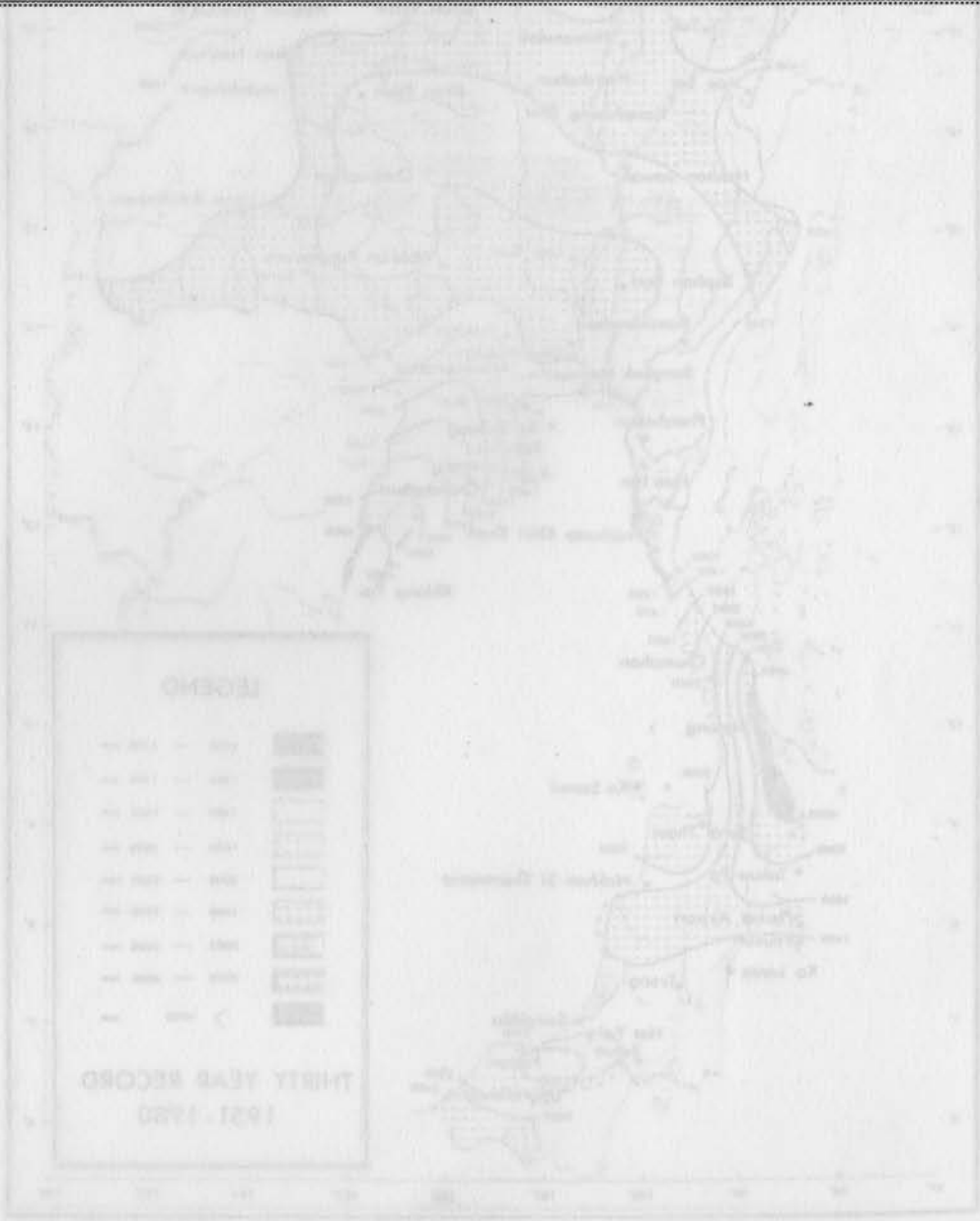

Map of Thailand Annual Rainfall

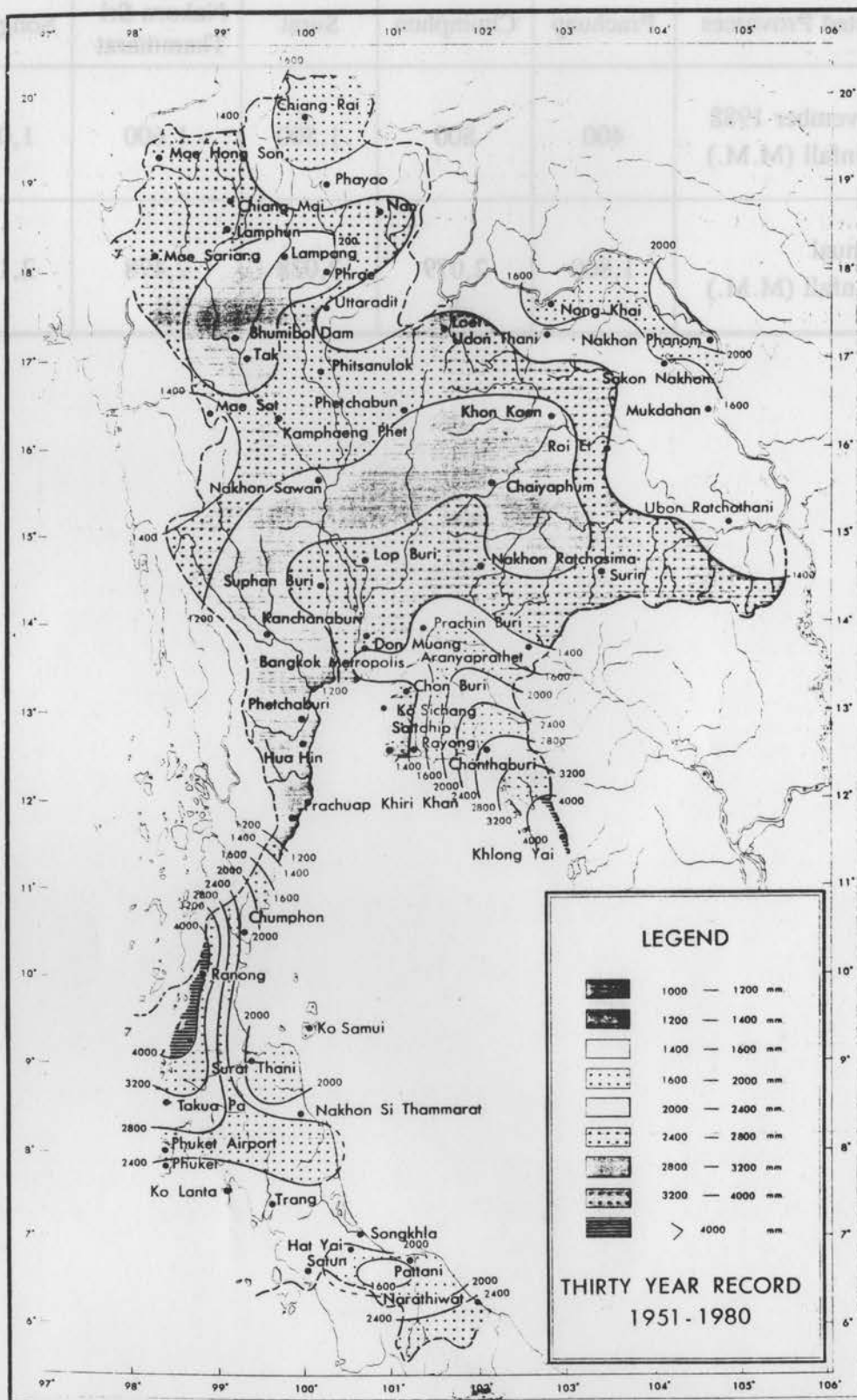

Chapter Three

DESCRIPTION OF THE PROBLEMS

During the rainy season between June and October, depressions from the South China Sea move southward to the region. Average rainfall within a 24-hour period or so could be as much as 400 mm., causing rapid flooding from elevated areas to low-lying land. Immediate evacuation is not possible. Many parts in Nakhon Sri Thammarat are flooded several times a year due to heavy rainfall on the Nakhon Sri Thammarat mountain range. Houses are submerged overnight and belongings are swept away, leaving the people with just the clothes on their back.

Typhoons occur towards the end of the rainy season, or around October to November when the cold spell strikes hot air in the Gulf of Thailand and the South China Sea, causing depressions to turn into typhoons which travel at a speed of over 100 km. per hour. On reaching the shore, typhoons can cause serious damage to buildings, houses and so on. Records at the Meteorological Department over the past 30 years reveal that typhoons of different velocities occur several times a year.

In 1988, heavy flooding in Nakhon Sri Thammarat and Surat Thani damaged as many as 30 secondary schools. In comparison, Typhoon Gay completely damaged six secondary schools and a greater number of primary schools. Wastage in economic and educational terms is apparent. As periodic restoration and/or reconstruction of school buildings disrupt the students' education and use up government funds, there is a real need to redesign school buildings and make them strong. Due consideration should be given to all details, including tile laying, window pane fixing, and so on.

Information collated from the survey

The South, the region most frequented by floods and typhoons, experiences heavy rainfalls which average some 2,300 mm. or about 168 days of rain all year round. This is exceptionally high. Buildings constructed on elevated ground may be safe from flooding, but they are subjected to the force of direct wind. This illustrates how one solution can give rise to another problem.

A. School layout

A school layout that ensures full protection against typhoons has yet to be developed. In some cases, buildings are raised above the ground level so that they are protected from being submerged in flash floods coming from the hills. In areas where flooding is a problem, schools are provided with a long ditch to receive water as well as to drain it. Schools that are located on low ground, where filling is not the answer, are provided with dikes that are high enough to prevent flooding.

The following flooding problems are common:

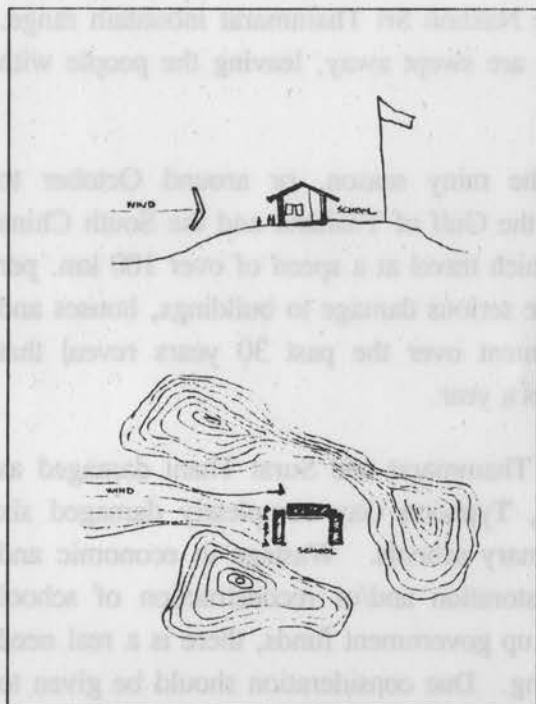

1. Many buildings are constructed on a low hill, thus subjecting them to direct wind.
2. Some buildings are constructed along the wind path, such as between hills or woods, thus subjecting them to strong winds in the monsoon. The buildings are vulnerable to roof flooding.
3. Tall trees are not properly grown. If grown densely enough alongside roads, they can reduce the wind speed. Buildings and trees should be properly spaced so that fallen trees do not damage nearby buildings.

4. Generally, buildings should have a north-south orientation to avoid direct sunlight and ensure better ventilation. Some must be parallel to the sea. In narrow quarters, strong winds generally come full blown from the sea.

B. Building design

Building design problems related to wind speed are associated with the following factors:

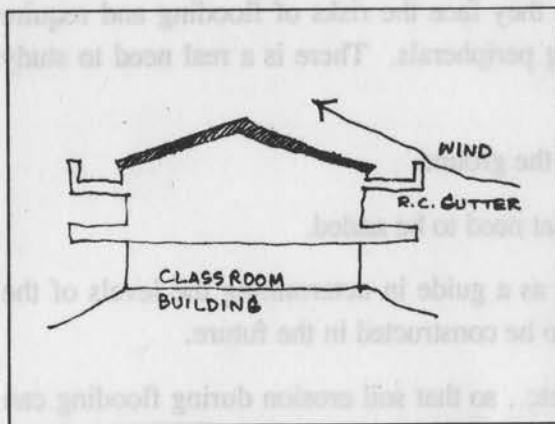

- Classroom size is large, mostly 7 x by 9 sq.m. The building must have a sufficient length measurement to withstand strong wind.
- Wind velocity of 120 km. per hour is not taken into account in the design of classroom buildings, hence making the roof, windows and sunshades vulnerable to wind damage.

- The roof structure is not durable enough to withstand strong winds. The rooves of buildings that have remained intact after a typhoon have been built with concrete slabs that are able to stand firmly against the wind and to change its direction. The roof structure must be firmly fixed to the top of the column.
- The strength of the windows, door panes and sunshades has not been duly considered. Most asbestos cement sunshades are damaged easily.

Certain drawbacks in the design of buildings in typhoon-prone areas are rooted in the following:

- Emphasis is given to the number of buildings constructed rather than their quality;
- Building design is not based on the need to guard against natural disasters caused by typhoons and floods, but is normally developed on the basis of general principles, such as wind and sun orientations, entrances, etc. It is necessary to develop standard requirements in order to minimize, if not prevent, damage caused by natural disasters.

C. Floods

Buildings constructed on elevated land could still get flooded if they are in a deforested area where, due to the absence of trees, rain water cannot be absorbed and thus flows down rapidly, submerging the surrounding areas.

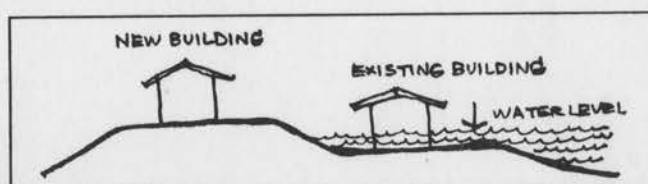

Land filling to raise the ground level is a common approach in constructing new buildings. Older buildings constructed 15

years ago or more stand on ground level where they face the risks of flooding and require constant maintenance of their floors and building peripherals. There is a real need to study the following ground factors:

1. Configuration, level and typology of the ground.
2. Existing sewage systems and those that need to be added.
3. Maximum heights of floods to serve as a guide in determining the levels of the buildings, roads and sports grounds to be constructed in the future.
4. Type of soil, such as sandy or clay, etc., so that soil erosion during flooding can be anticipated.
5. Previous flash flood pathways from the hills so that dikes can be constructed to help divert the water.
6. Storage and absorbent tanks to ease problems in using toilets during floods.

After the 1989 flood in Nakhon Sri Thammarat and Surat Thani, the main sewage system was improved to allow faster water flow into the sea. Flooding was further reduced as the pathway of floodwaters was studied, dikes were constructed in strategic areas, and more canals were dug so that the water could move faster. Hence, flood damage was minimized.

In mountainous areas, spillways should be constructed in the school grounds. The following suggestions should be considered for schools in such areas:

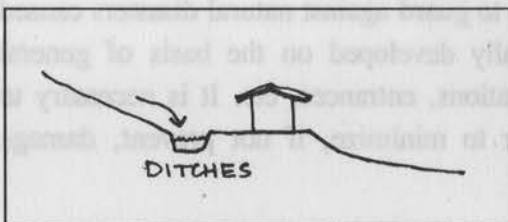

1. Ditches should be dug around the building or, if resources are adequate, around the entire school grounds to accommodate water flow and divert it to a nearby river or canal.

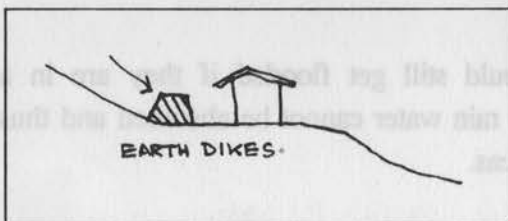

2. Earth dikes should be built on certain parts to soften the flow of water from the hills and divert it to a nearby river or canal by means of a drainage system.

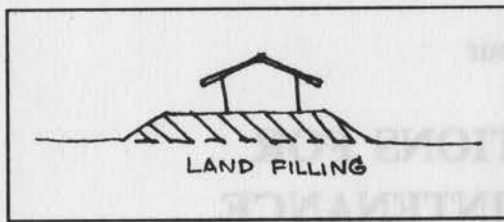

3. Additional land filling will help raise the ground level, allowing the water to flow more freely to lower areas.

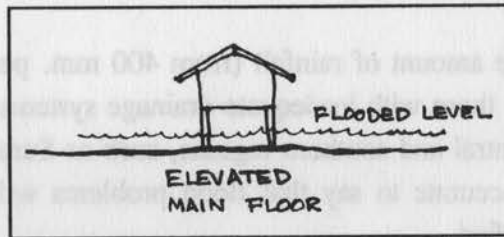

4. Construct buildings with elevated main floors, as in traditional Thai houses in the central region, hence raising the building above the flooded ground level. A nearby pool or reservoir can accommodate rain water and flash floods from the hills to prevent flooding of the school grounds.

Floods may come unexpectedly, catching the people unprepared. Some are too late for the people to avoid. Sometimes floodwaters are retained inside buildings for days or weeks, heavily damaging the lower part. The floodwaters should be removed as quickly as possible through draining, pumping or siphoning.

Before studying the recommendations, it is advised to consult the following checklist:

Task	Suggested Activities
1. Draining	<ul style="list-style-type: none"> • Pump water out from the entire building with portable generator sets in certain locations. • Holes and pipes below the ground floor. • Areas below the ground level. • Pumps and canals in the walls. • Cellars.
2. Cleaning	<ul style="list-style-type: none"> • Floods normally leave dirt behind (sand or mud, rubbish, leaves, litter, and clay) which gets stuck in crevices. • Remove mud from the floor and walls with jets. • Check and maintain the floor; submerged wooden floor must be cleaned. • Holes in the walls should be checked if mud.

Chapter Four

RECOMMENDATIONS FOR POST-FLOOD MAINTENANCE

The main cause of flooding is the excessive amount of rainfall (from 400 mm. per day) that is retained in low-lying areas, particularly those with inadequate drainage systems. Most of the flood-prone areas are located in the central and southern regions, such as Surat Thani and Nakhon Sri Thammarat. It is fairly accurate to say that flood problems will continue if reforestation programmes are not intensified.

Floods may come unexpectedly, catching the people unprepared. Some are too large for the people to avoid. Sometimes floodwaters are retained inside buildings for days or weeks, heavily damaging the lowest parts. The floodwaters should be removed as quickly as possible through draining, pumping or siphoning.

Before studying the recommendations, it is advisable to consult the following checklist:

Task	Suggested Activities
1. Draining	<p>Pump water out from the entire building with particular attention paid to certain locations:</p> <ul style="list-style-type: none">• Holes and pipes below the ground floor.• Areas below the ground level.• Passages and cavities in the walls.• Cellars.
2. Cleaning	<p>Floods normally leave dirt behind (such as mud, rubbish, leaves, litter, and clay) which gets stuck in crevices.</p> <ul style="list-style-type: none">• Remove mud from the floors and walls with jets.• Check underneath the floor; submerged wooden floor must be cleaned.• Holes in the walls should be cleared of mud.

<p>3. Drying</p>	<p>Drying up a building that has long been submerged in water is not easy, particularly if the building has many sections, some of which are vulnerable to wind and sunlight, or are in damp areas without adequate ventilation. Generally, the wall must be opened up so that ventilation can help dissipate moisture. If possible, heat should be applied over moist areas to minimize the bending and twisting of building materials, such as wood. The simplest way to speed up the drying process is to use mirrors to reflect sunlight over moist areas.</p> <ul style="list-style-type: none"> • Remove detachable items, such as window panes, rugs, furniture, etc. and dry them in the sunlight. • Provide ventilation to moist areas and areas underneath the building. • Open as many windows and doors as possible. • Dry up the floors and walls by cleaning and scrubbing.
<p>4. Oiling</p>	<p>Doors and window hinges should be inspected. Spraying or oiling should be applied to knobs, bolts, bearings, and sliding panels or their wheels, if any.</p>
<p>5. Inspection of the structure</p>	<p>In case the land is eroding or sinking, the following should be inspected:</p> <ul style="list-style-type: none"> • Horizontal structures, such as floors and rooves, to detect signs of imminent collapse. • General structures, such as pillars, beams and stairways, to detect signs of damage, e.g. cracks. • Cracks in the walls when the building is completely dry. • Ground-level footpath and stairways, to detect signs of damage.
<p>6. Building interior</p>	<p>Tight water pockets normally cause persistent moisture. The following actions should be taken:</p> <ul style="list-style-type: none"> • Check whether the floors, beams and other parts are affected by moisture, as evidenced by their twisting, bending or swelling. This could affect other parts of the building. • Before a major renovation, apply appropriate chemicals on the walls to protect them against fungi and insects. • Replace parts that are water-damaged, such as finishing surfaces, floor plates, wall finishes, etc. • Apply anti-rust substance on metal-based materials before painting. • Some of the wall-fixed furniture pieces must be removed to allow the wall to dry more quickly. Before re-fixing the furniture, the affected wall should be completely restored.

7. Electric wire	<p>Water can cause short-circuiting and other hazards. The following inspection should be carried out.</p> <ul style="list-style-type: none">• All switches should be lifted during a flood to guard against short-circuiting.• Authorities of local electrical power companies should be requested to inspect the power system after complete recession of the flood to ensure that the wiring system, plugs and switches are in order. Check locations which require repairs.• All insulation tubes or connectors between buildings must be completely free of moisture.• All electrical appliances, such as laundry machines, electric irons, etc., must be inspected for damage.
------------------	---

These routine inspections are recommended for most buildings. The list becomes more elaborate for large buildings or groups of buildings as their complexity increases. For example, maintenance of machinery and electrical power systems would need special attention. Immediate occupancy and/or use of a building that has recently been under water may be risky. All damp sections/parts should be thoroughly inspected.

After-flood maintenance, such as mud removal, is tedious and time-consuming. However, the task is not so bad for large areas, such as floors and walls, where water jets can be used with no difficulty. In multi-storey wooden-floor buildings, the upper floors can easily be cleaned, but the lower floors tend to be more problematical because the low ceilings make them less accessible. Mud usually gets stuck underneath the floors for long periods of time, and due to persistent moisture, the wood eventually gets twisted or swollen.

For concrete buildings where anti-moisture pads are used, the walls above the pads must be kept completely dry and free of mud. Even a trace of mud in the crevices can make the anti-moisture pads ineffective, as moisture could leak into the wall through the mud. Holes in the wall due to plumbing must be completely cleared of mud. Brick walls which have shed their concrete finish can hold at least 5 litres of water per square metre and would require a long time to dissipate moisture. Wood decorations at the base of the walls may have to be removed to allow the walls to dry up. The decorations can be restored afterwards. To ensure complete dryness of the building, a moisture metre is used to measure the moisture level of various sections, hence facilitating further restoration of the building.



Buildings damaged by flood and wind

Flood water that is a mix of fresh and sea water poses greater damage to building materials due to the salt components of sea water. Sea water takes longer to dry up than fresh water because of its water-holding property. It can cause more damage to metals and electric wires. Buildings in the south are not designed to withstand adverse factors in coastal areas. The concrete used is not mixed with anti-sulphate substance. Since sea water is more damaging, more thorough inspection should be carried out than in the case of normal flooding. Sulphate from the sea will soften the brick surface and cause it to chip off. If the bricks are submerged for several days, sulphate from the sea will erode the surface and cause it to peel off. This is also true for concrete blocks that have not been coated with anti-sulphate substance. When they are subjected to chemical reaction from the sea water for a long period of time, their surface will be affected and cracks may form.

The effect on the outer coating of a building that has been submerged in sea water for several days is quite pronounced. Cracks or chips due to erosion by sulphate salt from the sea weakens the adhesive property of the coating, in proportion to the amount of moisture from the sea permeating the surface of the brick wall.

The age of the building is another consideration. Buildings over thirty years old need frequent inspection and greater care.

Old buildings that are constructed on the principle of transferring the weight from the walls to the foundations differ greatly from modern buildings where the weight is transferred to the pillars and beams. Moisture can permeate old buildings more easily. Single layers of thick bricks will need longer periods of time to dry. Old brick layers are dry and the drier they are, the more water they can absorb during flooding. Hence, there is a greater chance of the inner and outer coats being damaged. Peeling off the coating to allow moisture to dissipate is one way of speeding up the drying process.

Old buildings often have wooden floors fastened to the beams and joists that are attached to the brick walls, thus making the wood highly susceptible to moisture, particularly old wood that is very dry. There is a great chance for this wood to twist, bend or swell. Therefore, better ventilation should be provided. Furthermore, prior to painting or coating, moisture should be measured to ensure that its level does not exceed 20 per cent. A wood preservative should be applied to the surface to ensure a longer life.

Buildings are like people or other utilities. The older they get, the more attention and maintenance they need. Building maintenance is not easy.



Maintenance of existing buildings

Chapter Five

CONSIDERATIONS FOR THE DESIGN OF TYPHOON-RESISTANT BUILDINGS

The task force surveyed typhoon-affected areas in Chumphon and Surat Thani to obtain data on damages to classroom and auxiliary buildings. It was found that the buildings were constructed based on a standard design for schools throughout the country and were not reinforced to withstand strong winds.

Wooden buildings of a conventional/standard design are more susceptible to damage than modern buildings utilizing a reinforced concrete structure. As it happened, Typhoon Gay seriously damaged wooden school buildings, completely destroying the upper sections. Only the pillars and beams were left standing. In contrast, buildings with reinforced concrete pillars and beams retained all the concrete parts, including the floors and certain roof structures. As for new-generation buildings constructed on foundations made entirely of reinforced concrete, only the rooves, doors and windows were blown away. All the brick walls were left intact.

A report on the effects of Typhoon Gay claimed that almost all semi-permanent buildings fell apart and a good number of permanent buildings were damaged. The working group on the maintenance and restoration of these buildings summarized the damages on standard-type permanent buildings as follows:

1. Rooves

- | | | |
|-----------|---|---|
| Tiles | - | all were blown away |
| Purlins | - | most were blown away |
| Rafters | - | some were blown away |
| Sunshades | - | most of the parts, especially tiles dangling from the roof, were blown away; some 40 per cent of the aluminum parts were blown away |
| Ceiling | - | almost all were blown away |

2. Windows and doors

Some 30-40 per cent of certain parts were blown away; while other parts needed repair and restoration.

3. Walls

- Asbestos sheets - most were broken
- Brickwork - remained intact
- Stairs - remained intact

4. Floors

- Wooden floors - about 30-50 per cent were damaged
- Concrete floors - remained intact

5. Auxiliaries

- Blackboards - most were damaged
- Desks and chairs - about 40-70 per cent needed repair

The survey team associated the extent of the damage with the types of materials used and the quality of workmanship. In normal cases, a reinforced concrete building could last up to 50 years if the materials used and the workmanship are of a high engineering standard. But when poor materials are used or the workmanship is sub-standard, repair will be needed five years after construction, particularly if the building is subjected to strong winds, as in the case of typhoons.

Photographs taken by the survey teams showed a two-storey building at Tha Kham Witthaya School, Chumphon, intact, although it was right in the path of Typhoon Gay. Except for a few, all the tiles remained fixed to the roof. This building was constructed in 1985 under the World Bank-assisted Community Secondary Schools Project which was implemented during 1981-1985. To get a complete picture, the engineer member of the team was interviewed. He explained:

The two-storey building was made of reinforced concrete. It had concrete floors. Because the concrete floors, beams and pillars were all cast in one piece, the building was particularly strong. Furthermore, its construction was closely supervised by a teacher who held a higher certificate in vocational education with specialization in construction. He had undergone intensive training in construction supervision as a condition of the World Bank loan, which required stringent engineering specifications to ensure long building life.

The engineer's report cited that the large-sized concrete roof gutter was able to accommodate large amounts of rain. This was suitable for buildings in heavy rainfall areas. The rims of the concrete gutter acted as a buffer against the strong wind, thus preventing the tiles from falling off. As it happened, only four tiles were out of alignment. Good quality sliding panels were used for the doors and windows enabling them to withstand the storm. The findings on this building shed light on the importance of building strength, choice of materials, and supervision of building construction in areas with strong winds.

The problems observed during the fiscal year in which the study was undertaken may be summarized as follows:

1. A major goal in the construction of buildings and their components was to achieve a target number of buildings, rather than to ensure building quality, strength, and durability.
2. Systematic monitoring and evaluation of construction were lacking, although there was a sufficient number of personnel to carry out such tasks, which were intended to be carried out each fiscal year.
3. There was no plan for the development of designs for specific provincial sites in the north, the central plain, and the south.
4. Investment funds for design, construction and development were insufficient, quite unlike the current practice in developed countries where initial outlays are set aside to ensure better construction and long building life.

This study is an initial step that will hopefully lead to further feasibility studies to raise the quality of school buildings to the standard followed in many western countries.

The western standard recognizes that school buildings, which are beautiful both in physical and architectural design, are conducive to the transfer of knowledge. In general, building construction carried out by the private sector is approaching western standard. In contrast, public buildings are hindered by widespread misconceptions among government officials that using inexpensive materials is economical. In fact, they do not appreciate the importance of using high quality construction materials, their major concern being to control the size of the annual budget for construction purposes. However, some agencies such as UNESCO have a better understanding of the problem. They have studied the building cost per student and have calculated how much should be invested per secondary school. Some considerations that should be taken into account are as follows:

Polished concrete floor may be less expensive than terrazzo, but the choice should be based also on building utilization and maintenance. Thus, decision makers should consider the actual utilization of school buildings and take into account the large number of students who will make use of them over a span of 50 years or so. Decision-makers should adopt a broader perspective and recognize that our secondary education institutions have only come half way between the standards in developed countries and those in under-developed countries.



Buildings damaged by Typhoon Gay on 3 November 1989

TYPHOON AFFECTED AREAS IN THAILAND

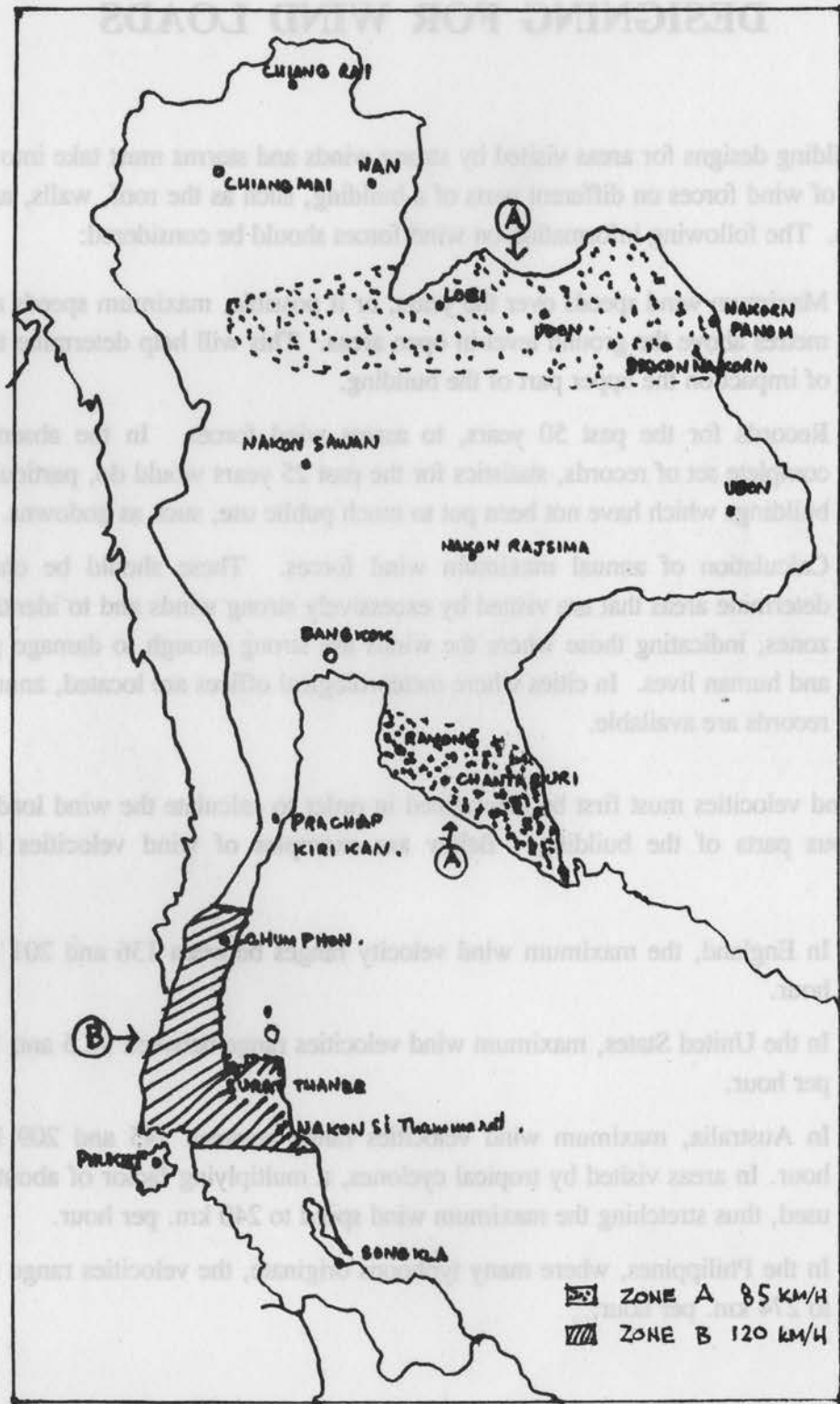

Chapter Six

DESIGNING FOR WIND LOADS

Building designs for areas visited by strong winds and storms must take into account the effects of wind forces on different parts of a building, such as the roof, walls, and other peripherals. The following information on wind forces should be considered:

1. Maximum wind speeds over the years, or if possible, maximum speeds about 10 metres above the ground level in open areas. This will help determine the point of impact on the upper part of the building.
2. Records for the past 50 years, to assess wind forces. In the absence of a complete set of records, statistics for the past 25 years would do, particularly for buildings which have not been put to much public use, such as godowns.
3. Calculation of annual maximum wind forces. These should be charted to determine areas that are visited by excessively strong winds and to identify wind zones, indicating those where the winds are strong enough to damage property and human lives. In cities where meteorological offices are located, annual wind records are available.

Wind velocities must first be determined in order to calculate the wind loads acting upon various parts of the building. Below are examples of wind velocities in other countries:

- ◆ In England, the maximum wind velocity ranges between 136 and 201 km. per hour.
- ◆ In the United States, maximum wind velocities range between 96.5 and 177 km. per hour.
- ◆ In Australia, maximum wind velocities range between 145 and 209 km. per hour. In areas visited by tropical cyclones, a multiplying factor of about 1.15 is used, thus stretching the maximum wind speed to 240 km. per hour.
- ◆ In the Philippines, where many typhoons originate, the velocities range from 32 to 274 km. per hour.

- ◆ In Thailand, records of damage caused by tropical cyclones have been compiled since 1947. Normally a tropical cyclone from the South China Sea would slow down into a tropical depression while passing over the Vietnamese border at a moderate wind speed but with widespread heavy rain.

Official records of the Meteorological Department in Bangkok show that each year Thailand is hit by several tropical depressions which cause widespread heavy rains across the country. Of a total of 148 tropical cyclones recorded, eight caused vast damage to buildings and houses. The cyclones are as follows:

1. An unidentified cyclone on 12 August 1941 made its path through Nakhon Phanom and Khon Kaen. Average speed: 80 km. per hour.
2. Cyclone Hie occurred on 12 August 1947 and made its path through Chanthaburi. It decelerated over Chonburi and turned into a tropical depression, causing heavy rains of up to 734 mm. in Chanthaburi, 461 mm. in Chonburi and 403 mm. in Bangkok. Average speed: 60 km. per hour.
3. Cyclone Harriet occurred on 26 October 1962 and moved across Nakhon Sri Thammarat. Average speed: 93 km. per hour. It completely devastated villages around Talumpak Peninsula.
4. Cyclone Tilda occurred on 23 September 1964 and made its path through Sakhon Nakhon, Udorn, and Pitsanulok before it decelerated. Average speed: 80 km. per hour.
5. Cyclone Doris occurred on 3 August 1969 and made its path through Sakhon Nakhon, Udorn, Khon Kaen and Pitsanulok before it finally decelerated. Average speed: 80 km. per hour.
6. Cyclone Ruth occurred on 30 November 1970 and passed through Nakhon Sri Thammarat. Average speed: 85 km. per hour.
7. Cyclone Sally occurred on 5 December 1972 and made its way through Surat Thani. Average speed 85 km. per hour.
8. Typhoon Gay occurred on 3 November 1989 and swept through Chumphon. It was the strongest wind ever. Average speed: 120 km. per hour.

Official records of the Meteorological Department also showed charts depicting the paths of the tropical cyclones, which may be divided into three types, namely:

1. Tropical depressions are tropical cyclones which decelerate to a speed not exceeding 61 km. per hour.
2. Tropical cyclones are strong whirling winds that decelerate from typhoons and move at a speed ranging from 61 to 117 km. per hour.

3. Tropical typhoons are strong winds with a speed exceeding 118 km. per hour close to the centre.

The above information shows that Thailand has experienced more tropical cyclones than typhoons, which occurred only once in 1989. The wind force that should be applied to determine the wind load at the 10 metre level above the ground should be between 60 and 120 km. per hour. The three zones for which a special building code should be applied are as follows:

1. Northeast zone : Mukdahan, Sakhon Nakhon, Nakhon Phanom, Udorn, Nongkhai, Loei, Pitsanulok, Uttaradit, Phrae and Nan.
2. East zone : Trad, Chanthaburi, Rayong and Chonburi.
3. South zone : Chumphon, Surat Thani and Nakhon Sri Thammarat.

To calculate the impact of the wind load on various parts of the building, use the following basic formula to determine the wind load from the standard velocity.

$$P = 0.0625 V^2$$

where V = the wind speed in metres per second, and

P = the equivalent static load in kg. per sq.m.

The static load of P is the force acting on the wall perpendicular to the wind direction.

Since buildings differ in design and characteristics, the effects of wind force vary. To derive the basic design load, the so-called drag-coefficient is applied. This is determined by analyzing the wind tunnel test.

If two buildings are parallel to each other, the value of the coefficient is increased since the two buildings are mutually supportive in obstructing the path of the wind.

Procedure to determine wind loads

In designing buildings in typhoon-affected areas, a procedure for determining wind loads should be adopted.

Step 1: Study of site data

- a) Determine the wind zones in various regions of the country by studying past records of zones that have experienced cyclones in the past 50 years.

- b) Study the highest wind speed ever recorded and use it as the basis for calculation.
- c) Categorize the types of building sites according to their geographical locations and the effects of the wind on them, as for example, coastal site, free-field site, covered site, etc. The geographical characteristics of the site will affect the coefficient of the wind loads.
- d) Fix the height of the building at 5 or 10 metres. Generally speaking, the higher the building, the greater are the wind loads to which it is subjected.
- e) Finally, determine the design pressure that would be exerted on the building.

Step 2: Determination of wind force

- a) Determine the building's dimensions that would be affected by the wind force (e.g. width, length and height). The wind force on the building is proportional to the size of the area against which the wind blows.
- b) Apply the coefficients of the wind force on the building's width, length and height.
- c) Calculate the weight of the different parts of the building structure, such as the weight of the walls, roofs, windows, etc.

Step 3: Determination of the wind load

- a) Calculate the wind force on the building.
- b) Analyze the wind force on the building structure to identify the vulnerable parts.
- c) Determine the point of impact, in order to arrive at a design that would provide each part with enough strength to withstand the calculated differential forces of the wind, such as walls, roofs, floors, etc.

Step 4: Detailed design of the connecting parts of the buildings, such as pillar and roof, window and wall, tiles and purlin, etc.

- a) Determine the configuration of these points.
- b) Design the wind load for each point.
- c) Specify the materials to be used to ensure firmness at each point. Proper reinforcement is necessary.
- d) Determine the fixing methods; for example, roof tiles which are normally fastened on hooks may have to be fixed with nails.

- e) Determine the level of skills required to ensure the quality of workmanship.
- f) Have the engineers inspect overturning moments and load areas regularly.

Several other important points should be considered to ensure proper building design. Here are some hints:

- ◆ In calculating the wind force, always take the average wind speed at the 10 metre level above the ground; and in determining the maximum speed, take the speed of the strongest cyclone ever recorded for the past 50 years.
- ◆ In calculating the wind force, make use of the most realistic coefficient that is most applicable to the location. For example, for an open area such as an airport, the coefficient will be higher than in an urban area where the wind speed is retarded by the density and proximity of buildings.
- ◆ The wind force becomes greater as the height of the building increases. By the same token, a building lower than 10 metres high will be subject to a lower wind force.
- ◆ The value of the wind force derived from the formula is the so-called free stream dynamic pressure, which is expressed in kg./sq.m., or pounds per square feet, or kilopascals. This value indicates the design pressure on parts of the building.
- ◆ The design pressure will vary according to the value of the coefficient which is the multiplying factor applicable to specific parts of the building.
- ◆ The wind load acting upon the building takes two forms. The first is the wind load acting on the size and shape of the building. The larger the size of the building, the greater is the area affected by the wind. This impact, in effect, will move the building forward, especially the wall and the roof. This is called the **structural load**.

The second is the residue force which is only moderate. It acts on the tiles, slide walls, etc. and is capable of blowing away tiles or window panes. It is known as the **cladding load**.

Formulae and coefficients for calculating wind forces

As a building has several parts and the calculating procedure is complex, steps must be spelled out to facilitate calculation.

1. To convert wind speed to dynamic pressure

While only one formula is used, that is, the wind force coefficient multiplied by the wind velocity, many scales are applied as follows:

Formula: $Q_z = C_v z^2$

where Q = Dynamic wind pressure

C = Coefficient

V_z = Dynamic wind velocity

Units: $Q_z = 0.613 V^2 \text{ N/m}^2$ (pascals) for V in metre per second

$Q_z = 0.0625 V^2 \text{ Kgf/m}^2$, for V in miles per second

$Q_z = 0.00226 V^2 \text{ lbf/ft}^2$, for V in miles per hour

2. Design wind pressure on a surface

Design wind pressure differs according to the characteristics of the surface of the building that obstructs the wind. This in turn varies according to the parts of the building and the wind direction.

$$P_z = C_p \cdot Q_z$$

where P_z = Design wind pressure

C_p = Coefficient of pressure

3. Coefficient for height

For a site in an open area, such as an airport, which falls within Terrain Category 2 that has a wind force second only to Terrain Category 1, the coefficients at different height levels are as follows:

0 - 5 metres high = 0.93

5 - 10 metres high = 1.00 (per datum)

10 - 15 metres high = 1.03

4. Coefficient for terrain categories

The coefficients vary according to the terrain category of the construction site. For a datum of 1.00 at a height of 10 metres on Terrain Category 2, the coefficient for each of the terrain categories is as follows:

Terrain Category 1 = 1.09 datum - e.g. at seaside

Terrain Category 2 = 1.00 - open country

Terrain Category 3 = 0.85 - urban area

Terrain Category 4 = 0.70 - city centre

5. Local pressure factors to walls and rooves

Refer to diagrams for typical areas affected.

General surface areas A	= 1.0
Perimeter areas B	= 1.5
Corners and gable ends C	= 2.0

The local pressure factor is multiplied by the external section on a roof or wall and affects the cladding and its supporting framework and fitting only. It must not be used to determine the total force on a building.

TERRAIN CATEGORIES - ROUGHNESS OF SITE

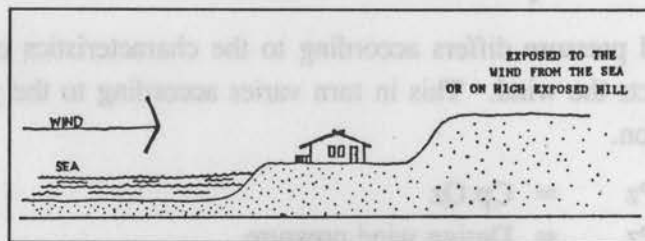

Terrain Category 1

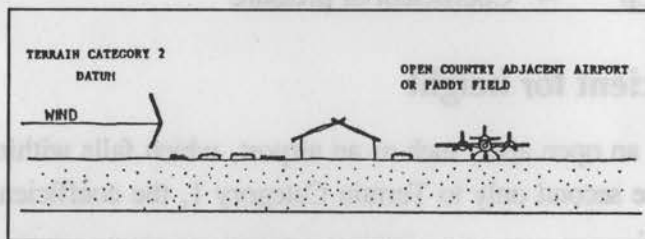

Terrain Category 2

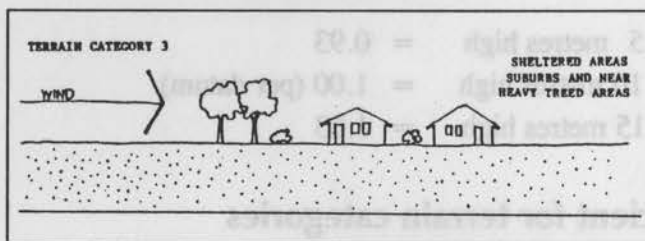

Terrain Category 3

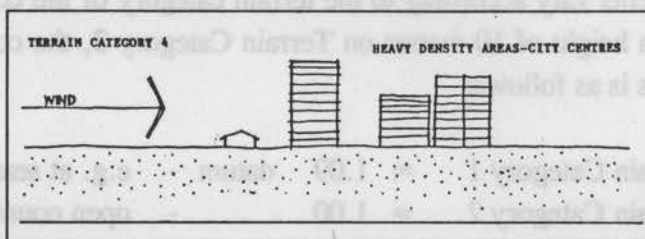

Terrain Category 4

Dynamic wind pressure – for site and height

Typhoon Gay had a peak velocity near the centre of over 60 knots (the speedometre in Chumphon is a conventional small type), or over 120 km. per hour. A study of the engineering framework design indicated that the safety factor for winds in the south was some 75 per cent higher than in other parts of the country. By municipal law, the lowest wind force at a building height of 10 metres is designated at 80 kg/sq.m. for the central region and 120 kg/sq.m. for the south. While the south has experienced cyclones several times, other regions have only experienced tropical depressions, with damage confined to buildings that have not conformed to municipal laws.

Table 1 shows the free stream dynamic pressures converted from corresponding wind speeds. In this table, a value one step higher than the force of Typhoon Gay is used to calculate the wind code.

Table 1.

Speed				Free Stream Dynamic Pressure			
m/sec	knots	mi/hr	km/hr	lbf/f ²	kgf/m ²	N/m ² Pa	Kpa
35.0	67.98	78.29	128.0	15.69	76.63	750.9	0.751
40.0	77.70	89.47	144.0	20.50	100.00	980.8	0.981
45.0	87.41	100.66	162.0	25.94	126.73	1,240.0	1.241

From the formula $P = 0.0625 V^2$ kgf/m² for V in miles/sec;
 Then $P = 0.0625 (40 \times 40)$ kgf/m²
 $= 100$ kgf/m²

A comparison of the wind code in this region appears as follows:

Philippines	= 250.0 kgf/sq.m.
Bangladesh	= 156.25 kgf/sq.m.
Australia	= 153.4 kgf/sq.m.
Sri Lanka	= 141.6 kgf/sq.m.
Viet Nam	= 112.9 kgf/sq.m.
Thailand	= 100.0 kgf/sq.m.

As Thailand is surrounded by many countries – Burma to the West and Viet Nam, Laos and Cambodia to the east, it has experienced less severe tropical cyclones compared with other countries in the region.

Table 2 shows the dynamic wind pressure of the site by Terrain Category at a height of 10 metres and 5 metres. Most secondary schools in South Thailand belong to Terrain Categories 2 and 3. Hence, discussions on the wind pressure on school buildings will be confined to these two terrain categories.

Table 2.

Terrain Category (site roughness)	Height (metres)	Velocity Multiplier	Wind Speed (mi/sec)	Dynamic Pressure (Qz in kgf/sq.m.)	
1.	10	1.09	43.6	119	Category for schools in South Thailand
	5	1.02	40.8	104	
2.	10	1.00	40.0	100	
	5	0.93	37.2	87	
3.	10	0.85	34.0	72	
	5	0.79	31.6	62	
4.	10	0.70	28.0	49	
	5	0.65	26.0	42	

Most schools in the south that were affected by cyclones showed damages in the roof framework and the upper part, while the foundations remained in good condition. The exceptions were buildings which did not conform to prescribed structural designs and were therefore completely damaged. Clearly, building designs for the south should pay particular attention to strengthening the roof.

Design Loads - Pitch < 20 Degrees

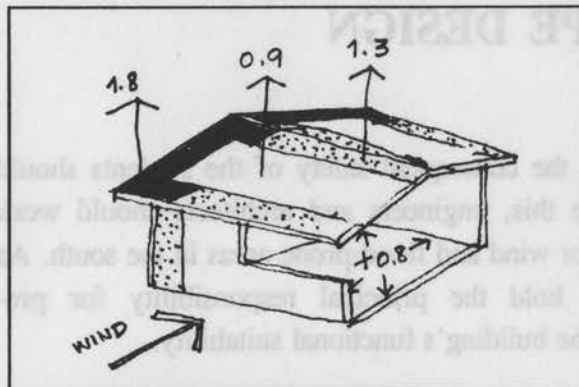

- Area A - $P_s + F_1$
- Area B - $1.5P_s + P_1$
- Area C - $2.0P_s + P_1$

Q_z = Static wind pressure
 P_z = Design pressure
 P_1 = Internal pressure
 P_s = External suction

Diagram of Pressure Coefficients
 (to be multiplied by Q_z)

Structural load $P_z = Q_z (P_1 + P_s)$
 Cladding load $P_z = Q_z (K \times P_s + P_1)$

Table 3.

Terrain Category	Height m	Pressure Q_z	Area A $1.7 \times Q_z$	Area B $2.15 \times Q_z$	Area C $2.6 \times Q_z$	Wind Speed m/sec
1	10	119	202	258	309	43.6
	5	104	177	224	270	40.8
2	10	100	170	215	260	40.0
	5	87	148	187	226	37.2
3	10	72	122	155	187	34.0
	5	62	105	133	161	31.6
4	10	49	83	105	127	28.0
	5	42	71	90	109	26.0
			Structural Load	Cladding Loads*		

*Roof Loads - Dominant opening in windward wall

Local pressure factors must not be used in determining the total force on a structure or a surface, such as a wall or roof.

PROTOTYPE DESIGN

The strength of school buildings and the consequent safety of the students should always be our primary concern. To ensure this, engineers and architects should work closely in designing multi-purpose buildings for wind and flood-prone areas in the south. As commonly practiced at present, architects hold the principal responsibility for pre-determining the site, the wind direction, and the building's functional suitability.

In the design stage, two problems should be solved simultaneously. First is the problem of flash floods, resulting from the flow of rain water from the hills to low-lying areas. Second is the problem associated with wind speeds exceeding 120 km. per hour. The following diagram outlines the two-pronged problem and the two functions of the building:

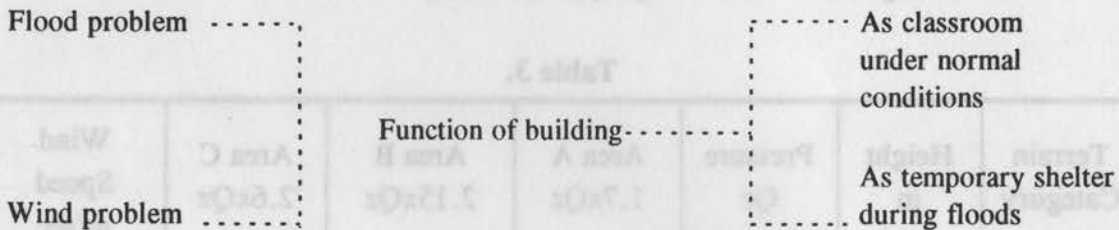

A. Determining the functions of a building

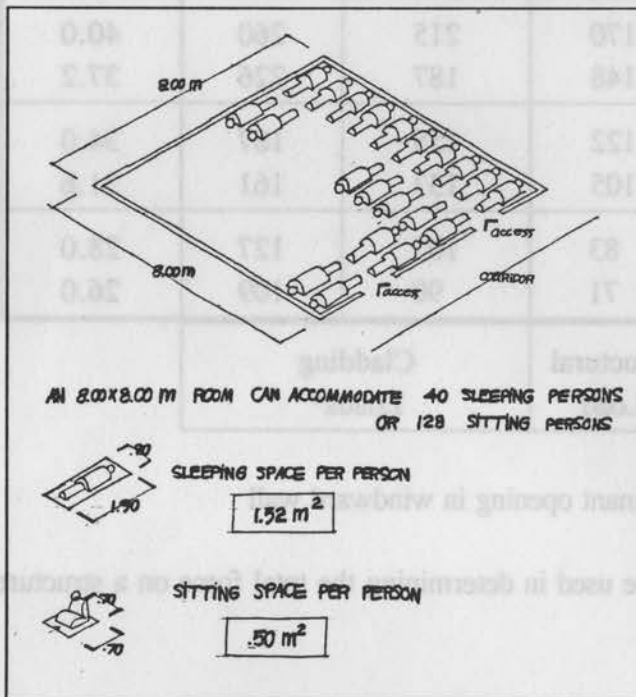

The architect plays a major role in studying the functions of a building. Converting a class-room into a temporary dormitory may appear simple, but an average classroom space of 1.4 sq.m. per student is inadequate for the purpose. The architect must assess what would be a suitable and economical room size, to suit both functions: as a classroom under normal circumstances and as a temporary dormitory during an emergency. Clearly, human needs and sleeping habits must be duly considered.

Each person occupies about 0.80 x 1.90 sq.m. of space. A standard 8.00 x 8.00 sq.m. classroom can accommodate a total of 40 students. Therefore, for a class size of 45 students, only 40 can be accommodated in the temporary dormitory.

As the design of the prototype building was a pilot project, a small-sized building was considered appropriate. A large-sized building would mean a larger investment and would require more complex construction procedures. Small units can be combined to form one large unit. For this feasibility study, the Task Force opted to design a multi-purpose building consisting of four classrooms that can hold 45 students each or a total of 180 students.

Other basic structures, such as corridors and stairways, should be provided. In keeping with the architectural design of houses in the central part of Thailand, the ground floor is left as an open space and used as a multi-purpose area. In effect, it helps to keep the building safe from flood water.

B. Analysis of the flood problem

According to a survey mission report on the southern flood in 1989, the flood was caused by torrential rainfall which averaged more than 400 mm. within 24 hours. Flash floods from the hills and the highlands submerged low-lying areas as sandbags and earth dams failed to divert excess water into the canals.

At the time of the major flood in Surat Thani and Nakhon Sri Thammarat in 1989, the south was struck by a tropical cyclone, causing rainfall that lasted for a whole week. The situation was aggravated by a coincidental ebb tide, which gathered rain water on the shore and caused a big flood.

As mentioned above, flooding can be reduced if the ground area of a building is left as an open space. Such space could be used as a multi-purpose learning area. The provision of a rooftop heliport could further enhance a building's usefulness. A heliport is vital to such rescue operations as supplying food or transporting students to a safe place. For this purpose, the roof must be made of concrete.

C. Considerations for the wind problem

The following are basic considerations that should be incorporated in the building design:

1. The building should be strong enough to resist a wind speed of 144 km. per hour.

2. The foundation and the columns should be able to resist the pressure of water flowing from the hills.
3. Besides its own weight, the building should be able to support the aggregate weight of all the students who are gathered in the same room during a cyclone. The roof should be strong enough to support the weight of a helicopter in case one is used during a rescue operation.
4. The windows and doors should be of the sliding type. They should be fastened to the walls by pulleys. For ordinary panes, the wall should be solid and sufficiently strong to withstand the impact of the wind.
5. The staircase design should be of a strong design.
6. As an open ground floor allows the flow of water from the hills with least damage to the building's framework, it should be given due consideration in the building design.

One of the main concerns of the Task Force was the higher cost incurred compared to the cost of a standard classroom building. As the frequency of floods and cyclones occurring in specific areas cannot be accurately predicted, it is rather difficult to arrive at a figure that would vouch for the cost effectiveness of the project some 30 years after its construction. The Task Force decided to leave this matter with the Bureau of Budget. In Chulaporn village in Chumphon, construction costs for a school recently built were reduced by making use of free labour and equipment supplied by the engineering section of the Royal Thai Army.

1. Basic requirements for a safe structure

- a. **Anchorage.** Every point of the structure should be firmly anchored to the foundations, with the specified strength conforming to engineering principles to enable it to resist the wind force.
- b. **Bracing.** All walls and rooves should be firmly braced to the structure to prevent them from falling off the frames.
- c. **Continuity.** Continuity of strength should be provided to all points of the building from the foundations up to the roof as an integrated concrete structure, thus enabling the building to resist both vertical and horizontal forces.

2. Masonry wall

The masonry wall should be strengthened to overcome potential weaknesses. One such weakness could be caused by poor windows or doors that reduce the building's strength considerably. These may be reinforced by putting secondary columns around them, thus strengthening their adhesion to the brick work. A wind velocity of 162 km. per

hour is capable of blowing bricks away. To prevent this, add secondary columns that are made of reinforced concrete at 1.50 metre intervals, thus integrating the brick work to the concrete beams and reinforcing the adjacent main columns. The strength of the brick walls can be enhanced as follows:

- a. Place a lintel on top of every brick wall.
- b. Place concrete secondary columns at 1.50 m. intervals, stretching from the floor beam to the lintel beam.
- c. If the wall is very high, reinforce the brick work by placing a small beam **between** the wall at a point underneath the window **and** the upper lintel on top of the window.

3. Roof

The dimensions of the eaves should be carefully considered. If the eaves are too long, the wind force may cause the Monroe effect. In the Philippines, which experience the strongest typhoons in the Asian region, the length of eaves has been shortened from 2.25 m. to 1.20 m. to reduce the surface area affected by the wind.

To provide a heliport for helicopters, a flat slab is placed on the roof firmly affixing the whole roof area to the surrounding roof beams, thus constituting an integrated framework. It is the engineer's responsibility to reinforce the strength of the flat slab to tolerate a pre-determined wind force.

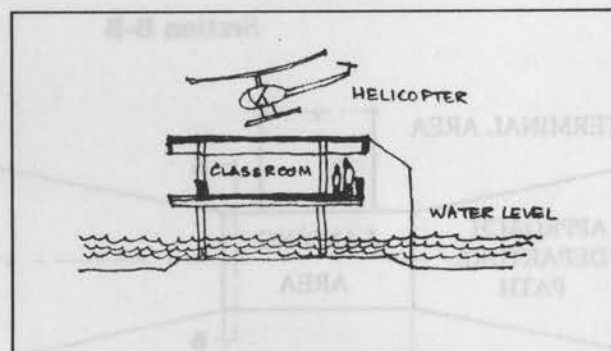

Open wall frees ground floor

HELIPORTS

Minimum Gross Weight (Bell 204) = 1,000 kg.

Maximum Gross Weight (Sikorski 5-56) = 14,000 kg.

Speed (average) = 150-220 kph. (km./hr.)

Site Selection HELIPORTS

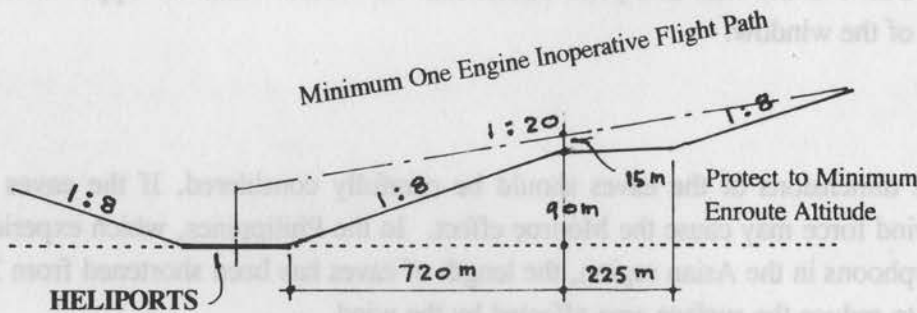

Figure 1. Obstructions in approach area

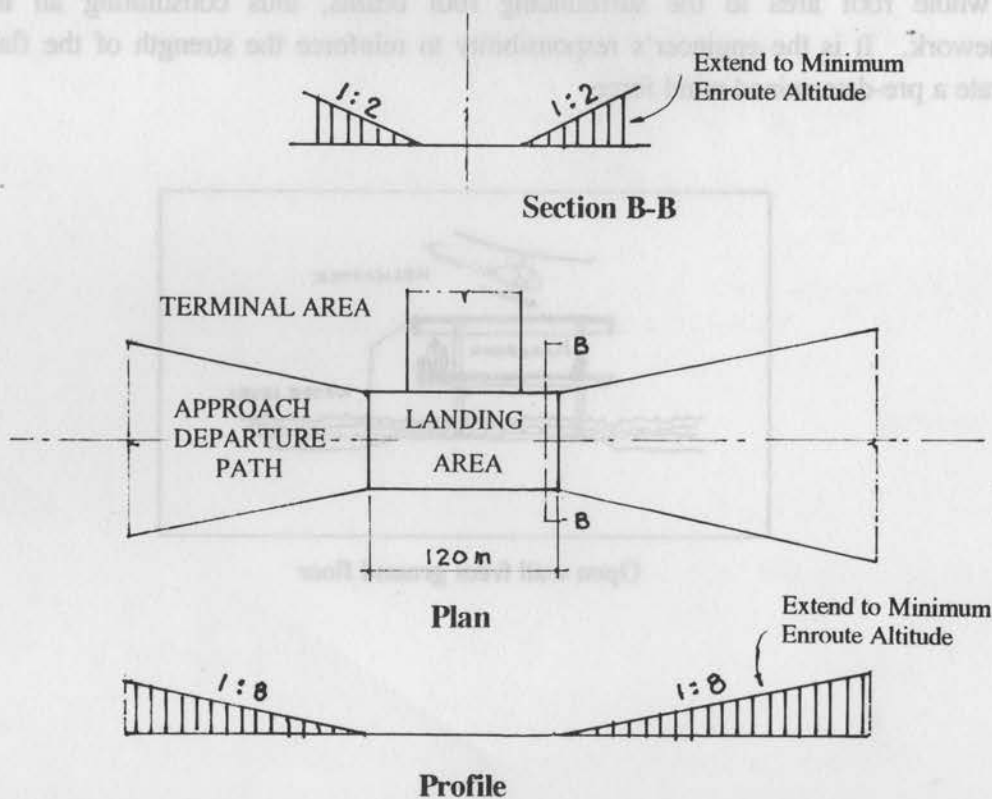
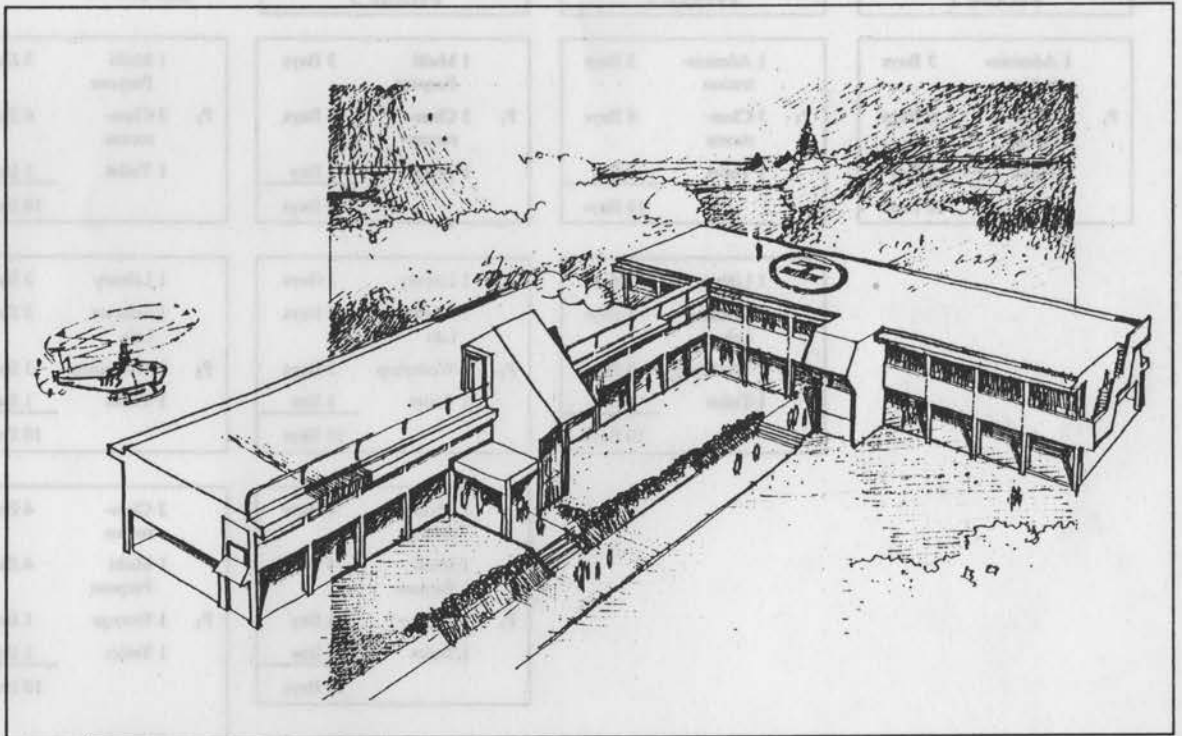

Figure 2. FAA Recommendations for approach departure obstruction clearance

DEVELOPMENT PLAN
SCHEDULE OF ACCOMMODATIONS



Multi-purpose buildings for disaster situations

DEVELOPMENT PLAN SCHEDULE OF ACCOMMODATIONS

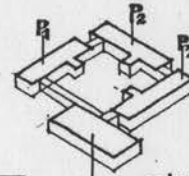
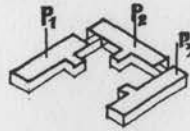
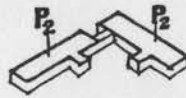
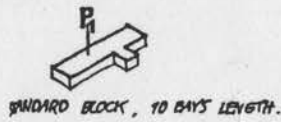

PHASE 1	PHASE 2	PHASE 3	EXPANSION																																
<table border="1"> <tr> <td>1 Administration</td> <td>3 Bays</td> </tr> <tr> <td>P₁ 3 Class-rooms</td> <td>6 Bays</td> </tr> <tr> <td>1 Toilet</td> <td>1 Bay</td> </tr> <tr> <td></td> <td><u>10 Bays</u></td> </tr> </table>	1 Administration	3 Bays	P ₁ 3 Class-rooms	6 Bays	1 Toilet	1 Bay		<u>10 Bays</u>	<table border="1"> <tr> <td>1 Administration</td> <td>3 Bays</td> </tr> <tr> <td>P₁ 3 Class-rooms</td> <td>6 Bays</td> </tr> <tr> <td>1 Toilet</td> <td>1 Bay</td> </tr> <tr> <td></td> <td><u>10 Bays</u></td> </tr> </table>	1 Administration	3 Bays	P ₁ 3 Class-rooms	6 Bays	1 Toilet	1 Bay		<u>10 Bays</u>	<table border="1"> <tr> <td>1 Multi Purpose</td> <td>3 Bays</td> </tr> <tr> <td>P₁ 3 Class-rooms</td> <td>6 Bays</td> </tr> <tr> <td>1 Toilet</td> <td>1 Bay</td> </tr> <tr> <td></td> <td><u>10 Bays</u></td> </tr> </table>	1 Multi Purpose	3 Bays	P ₁ 3 Class-rooms	6 Bays	1 Toilet	1 Bay		<u>10 Bays</u>	<table border="1"> <tr> <td>1 Multi Purpose</td> <td>3 Bays</td> </tr> <tr> <td>P₁ 3 Class-rooms</td> <td>6 Bays</td> </tr> <tr> <td>1 Toilet</td> <td>1 Bay</td> </tr> <tr> <td></td> <td><u>10 Bays</u></td> </tr> </table>	1 Multi Purpose	3 Bays	P ₁ 3 Class-rooms	6 Bays	1 Toilet	1 Bay		<u>10 Bays</u>
1 Administration	3 Bays																																		
P ₁ 3 Class-rooms	6 Bays																																		
1 Toilet	1 Bay																																		
	<u>10 Bays</u>																																		
1 Administration	3 Bays																																		
P ₁ 3 Class-rooms	6 Bays																																		
1 Toilet	1 Bay																																		
	<u>10 Bays</u>																																		
1 Multi Purpose	3 Bays																																		
P ₁ 3 Class-rooms	6 Bays																																		
1 Toilet	1 Bay																																		
	<u>10 Bays</u>																																		
1 Multi Purpose	3 Bays																																		
P ₁ 3 Class-rooms	6 Bays																																		
1 Toilet	1 Bay																																		
	<u>10 Bays</u>																																		
	<table border="1"> <tr> <td>1 Library</td> <td>3 Bays</td> </tr> <tr> <td>1 Science Lab</td> <td>3 Bays</td> </tr> <tr> <td>P₂ 1 Workshop</td> <td>3 Bays</td> </tr> <tr> <td>1 Toilet</td> <td>1 Bay</td> </tr> <tr> <td></td> <td><u>10 Bays</u></td> </tr> </table>	1 Library	3 Bays	1 Science Lab	3 Bays	P ₂ 1 Workshop	3 Bays	1 Toilet	1 Bay		<u>10 Bays</u>	<table border="1"> <tr> <td>1 Library</td> <td>3 Bays</td> </tr> <tr> <td>1 Science Lab</td> <td>3 Bays</td> </tr> <tr> <td>P₂ 1 Workshop</td> <td>3 Bays</td> </tr> <tr> <td>1 Toilet</td> <td>1 Bay</td> </tr> <tr> <td></td> <td><u>10 Bays</u></td> </tr> </table>	1 Library	3 Bays	1 Science Lab	3 Bays	P ₂ 1 Workshop	3 Bays	1 Toilet	1 Bay		<u>10 Bays</u>	<table border="1"> <tr> <td>1 Library</td> <td>3 Bays</td> </tr> <tr> <td>1 Science Lab</td> <td>3 Bays</td> </tr> <tr> <td>P₂ 1 Workshop</td> <td>3 Bays</td> </tr> <tr> <td>1 Toilet</td> <td>1 Bay</td> </tr> <tr> <td></td> <td><u>10 Bays</u></td> </tr> </table>	1 Library	3 Bays	1 Science Lab	3 Bays	P ₂ 1 Workshop	3 Bays	1 Toilet	1 Bay		<u>10 Bays</u>		
1 Library	3 Bays																																		
1 Science Lab	3 Bays																																		
P ₂ 1 Workshop	3 Bays																																		
1 Toilet	1 Bay																																		
	<u>10 Bays</u>																																		
1 Library	3 Bays																																		
1 Science Lab	3 Bays																																		
P ₂ 1 Workshop	3 Bays																																		
1 Toilet	1 Bay																																		
	<u>10 Bays</u>																																		
1 Library	3 Bays																																		
1 Science Lab	3 Bays																																		
P ₂ 1 Workshop	3 Bays																																		
1 Toilet	1 Bay																																		
	<u>10 Bays</u>																																		
		<table border="1"> <tr> <td>2 Class-rooms</td> <td>4 Bays</td> </tr> <tr> <td>1 Multi Purpose</td> <td>4 Bays</td> </tr> <tr> <td>P₃ 1 Storage</td> <td>1 Bay</td> </tr> <tr> <td>1 Toilet</td> <td>1 Bay</td> </tr> <tr> <td></td> <td><u>10 Bays</u></td> </tr> </table>	2 Class-rooms	4 Bays	1 Multi Purpose	4 Bays	P ₃ 1 Storage	1 Bay	1 Toilet	1 Bay		<u>10 Bays</u>	<table border="1"> <tr> <td>2 Class-rooms</td> <td>4 Bays</td> </tr> <tr> <td>1 Multi Purpose</td> <td>4 Bays</td> </tr> <tr> <td>P₃ 1 Storage</td> <td>1 Bay</td> </tr> <tr> <td>1 Toilet</td> <td>1 Bay</td> </tr> <tr> <td></td> <td><u>10 Bays</u></td> </tr> </table>	2 Class-rooms	4 Bays	1 Multi Purpose	4 Bays	P ₃ 1 Storage	1 Bay	1 Toilet	1 Bay		<u>10 Bays</u>												
2 Class-rooms	4 Bays																																		
1 Multi Purpose	4 Bays																																		
P ₃ 1 Storage	1 Bay																																		
1 Toilet	1 Bay																																		
	<u>10 Bays</u>																																		
2 Class-rooms	4 Bays																																		
1 Multi Purpose	4 Bays																																		
P ₃ 1 Storage	1 Bay																																		
1 Toilet	1 Bay																																		
	<u>10 Bays</u>																																		
			<table border="1"> <tr> <td>Cafeteria and Other Facilities</td> <td></td> </tr> </table>	Cafeteria and Other Facilities																															
Cafeteria and Other Facilities																																			

PHASE I: BUILDING PLAN

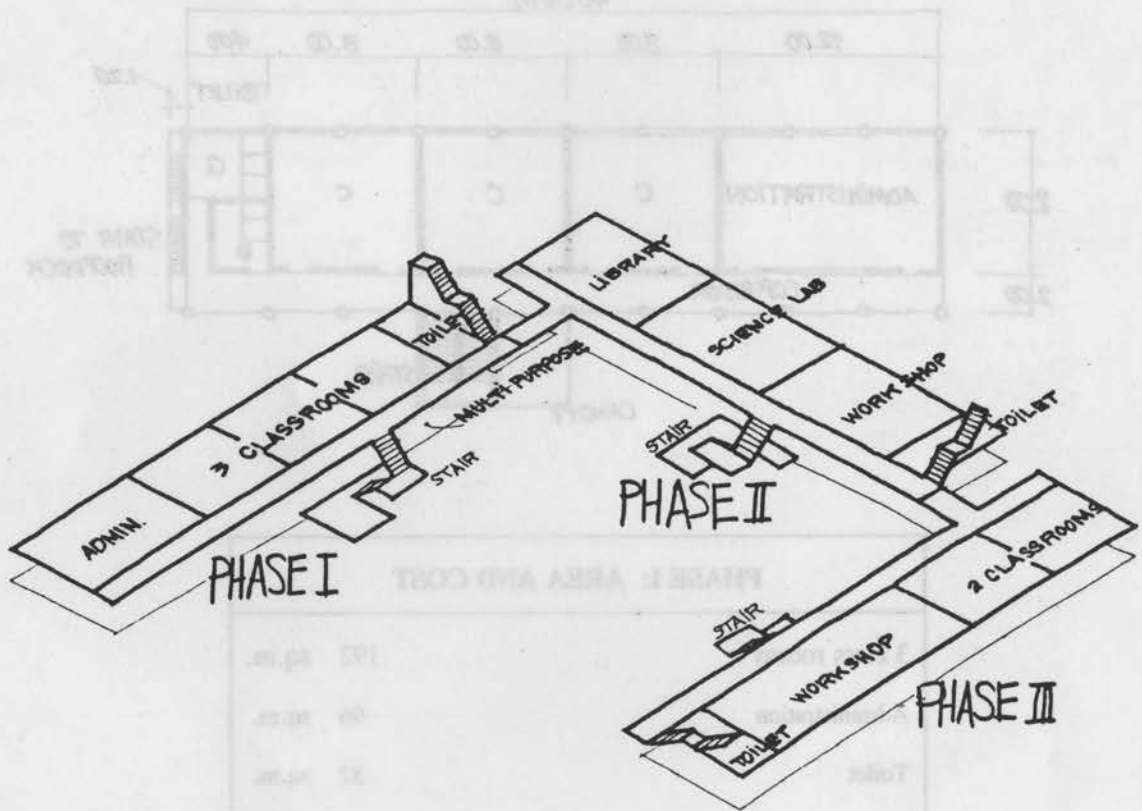

Functional relationships

Cost of building	282,780
Total area	679 sq. m.
Estimated cost US\$110 per sq. m.	249,000
Ground floor for multi-purpose	400 sq. m.
Estimated cost US\$230 per sq. m.	218,000
Estimated cost US\$230 per sq. m.	218,000

PHASE I: BUILDING PLAN

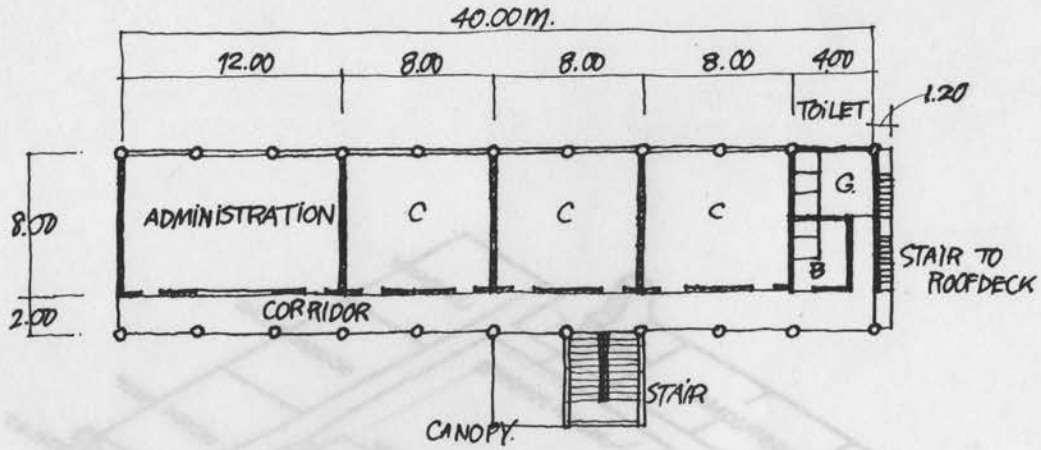

PHASE I: AREA AND COST		
3 class rooms	192	sq.m.
Administration	96	sq.m.
Toilet	32	sq.m.
Circulation	155	sq.m.
Total Area	539	sq.m.
Estimated cost US\$220 per sq.m.	\$118,580	sq.m.
Ground floor for multi-purpose	400	sq.m.
Estimated cost US\$110 per sq.m.	\$44,000	sq.m.
Total area	939	sq.m.
Cost of building	\$162,580	

DESIGN CONCEPT

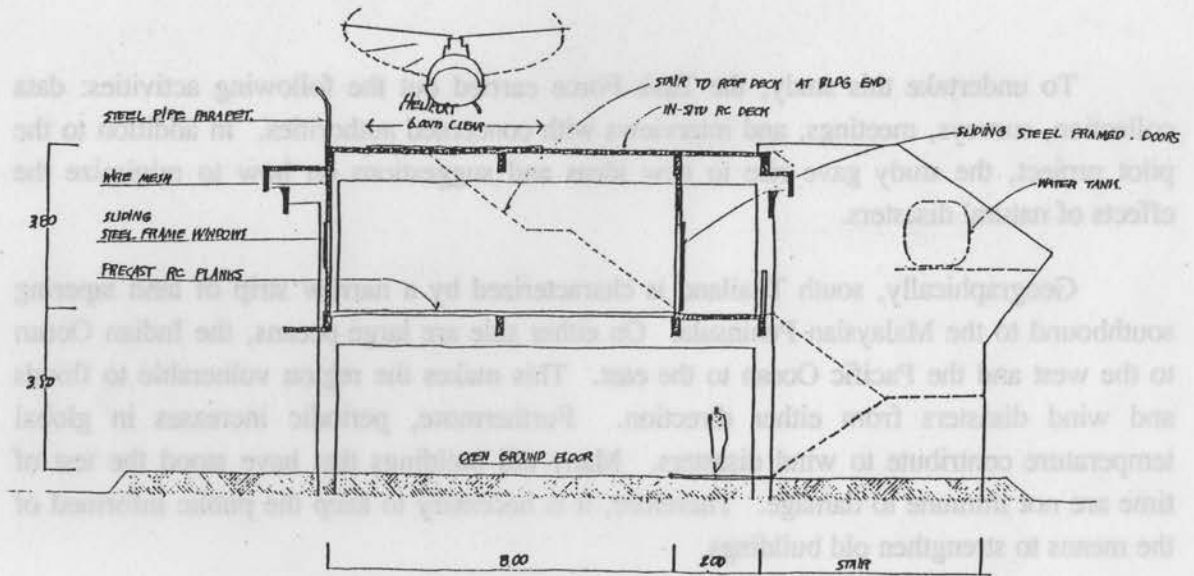

Building cross section

Chapter Eight

RECOMMENDATIONS AND APPLICATIONS

To undertake this study, the Task Force carried out the following activities: data collection, surveys, meetings, and interviews with concerned authorities. In addition to the pilot project, the study gave rise to new ideas and suggestions on how to minimize the effects of natural disasters.

Geographically, south Thailand is characterized by a narrow strip of land tapering southbound to the Malaysian Peninsula. On either side are large oceans, the Indian Ocean to the west and the Pacific Ocean to the east. This makes the region vulnerable to floods and wind disasters from either direction. Furthermore, periodic increases in global temperature contribute to wind disasters. Many old buildings that have stood the test of time are not immune to damage. Therefore, it is necessary to keep the public informed of the means to strengthen old buildings.

Further action should be taken in the following areas:

1. Technical aspects

Technical papers must be prepared and distributed in flood and wind-affected areas. The papers should deal with building maintenance, involving such components as the rooves, windows and doors.

2. Administrative aspects

A seminar for school administrators and concerned staff should be conducted to inform them of the nature of problems related to flash floods and cyclones, with a view to providing common knowledge and understanding. While the seasonal occurrence of certain natural disasters can be anticipated, their damage potential cannot always be accurately predicted. Nevertheless, this can be minimized through disaster preparedness.

3. Research and development

Research and development should be a continuous undertaking. Buildings should be evaluated after the occurrence of natural disasters to ascertain their level of safety and the need to repair or modify damaged sections.

Future activities of the project

The prototype developed by the Task Force is a concept design, and departmental decision makers who endorsed it should allow more time for further study, particularly in design development and preparation of construction documents. The building site will be selected once these tasks are completed and approval has been granted by the concerned authorities.

Unlike standard school buildings which are evaluated by an independent team one year after construction, multi-purpose school buildings in natural disaster-prone areas are evaluated after a natural disaster has occurred to investigate all probable damage.

1. Establishment of wind zones in Southern Thailand. Two zones may be identified in terms of wind velocities.
2. Development of building specifications, particularly those affecting the joints between major parts, such as between the roof framework and the columns, with a view to strengthening existing buildings.
3. Damages caused by underground water acting on the basic foundations of the building.
4. Regular maintenance of existing buildings, based on a feasible schedule and supported by an adequate budget.
5. Public education on matters related to disaster mitigation.
6. Landscaping of the school grounds to ensure better drainage or the flow of flood water from the school grounds.

The Task Force hopes that this study will benefit the planning of school buildings and facilities in areas prone to natural disasters. It urges continued support for research and development in these areas by concerned government authorities and other parties.

SUMMARY

This report seeks to assist primary and secondary schools in Southern Thailand to overcome problems caused by natural disasters which occur almost every year. The Government should ensure that adequate contingency funds to repair damaged buildings and facilities are provided.

This study has marked a first step towards the solution of problems caused by natural disasters. Support from the Government and concerned agencies will contribute to further develop this work, as well as other studies in the future, thus directly benefiting education in rural Thailand. From a broader perspective, other buildings, including private houses, will also benefit from this study.

The study calls on decision makers to tackle these issues. Future studies are recommended on the following topics:

1. Establishment of wind zones in Southern Thailand. Two zones may be identified in terms of wind velocities.
2. Development of building specifications, particularly those affecting the joints between major parts, such as between the roof framework and the columns, with a view to strengthening existing buildings.
3. Damages caused by underground water acting on the basic foundations of the building.
4. Regular maintenance of existing buildings, based on a feasible schedule and supported by an adequate budget.
5. Public education on matters related to disaster mitigation.
6. Landscaping of the school grounds to ensure better drainage or the flow of flood water from the school grounds.

The Task Force hopes that this study will benefit the planning of school buildings and facilities in areas prone to natural disasters. It urges continued support for research and development in these areas by concerned government authorities and other parties.

BIBLIOGRAPHY

- UNESCO. *Typhoon Resistant School Building for Viet Nam*. Bangkok, 1987.
- UNESCO. *Cyclone-resistant Rural Primary School Construction – a Design Guide*. Bangkok, 1977.
- UNESCO. *Educational Building Design*. Nanying, China, 1988.
- UNESCO. *UNESCO Mission to Sri Lanka, December 1989. Report of June 1989 Floods*. Bangkok, 1989.
- UNESCO. *Primary School Buildings for Flooded Areas in Bangladesh*. Bangkok, 1988.
- UNESCO. *Education Buildings in Cyclone Regions*. Training School, Manila, 1986.
- BRE Digest. *Building Defects and Maintenance*. London, 1977.
- Meteorological Department. *Annual Climatological Data of Thailand*. Bangkok, 1989.
- Meteorological Department. *Climatological Data of Thailand – 30 Year Period (1956-1985)*. Bangkok, 1989.
- Meteorological Department. *The Cyclone "Gay": Report, 31 October - 4 November 1989*. Bangkok, 1989.
- Meteorological Department. *Mean Annual and Monthly Rainfall over Thailand, 1951-1908*. Bangkok, 1984.
- Meteorological Department. *The Climate of Thailand*. Bangkok, 1987.
- Meteorological Department. *Tracks of Tropical Cyclones over Thailand and its Neighbouring Areas, 1985-1980*. Bangkok, 1989.
- McGraw-Hill. *Time Saver Standards*. New York, 1989.
- General Education Department. *Report of Schools Damaged by Cyclone "Gay"*. November 1989. (In Thai).

ANNEXES

Annex I

AIRFOIL EFFECT: WHEN ROOVES FLY

Velocity	Typical Movement
0.00 m/sec	Dead calm - Birds fly
0.23 m/sec	Leaf moves
0.50 m/sec	Leaf flies
0.75 m/sec	Paper flies
0 - 5 m/sec	
5 - 10 m/sec	Loose aluminum sheets fly
10 - 15 m/sec	Loose galvanized iron sheets fly
15 - 20 m/sec	Loose fiber cement sheets fly
20 - 25 m/sec	
25 - 30 m/sec	Loose concrete and clay tiles fly
30 - 35 m/sec	Roof sheets fixed to battens fly
35 - 40 m/sec	DC3 aircraft take off speed
40 - 45 m/sec	Roof tiles nailed to battens fly
45 - 50 m/sec	Garden walls blow over
50 - 55 m/sec	
55 - 60 m/sec	
60 - 65 m/sec	100 mm thick concrete slabs fly
65 - 70 m/sec	
70 - 75 m/sec	150 mm thick concrete slabs fly
75 - 80 m/sec	
80 - 85 m/sec	
85 - 90 m/sec	
90 - 95 m/sec	
95 - 100 m/sec	250 mm thick concrete slabs fly

Annex II

Task Force

1. Mr. Kriangsak Charayanond Chairman
2. Mr. Paiboon Charoensuk
3. Mrs. Payao Buachan
4. Mr. Ekkapong Fangeon
5. Mr. Tienchai Chantarawan
6. Mr. Kamtorn Bunpalit
7. Mr. Bunlue Sreepichai Secretary

Advisor

Mr. Kriengkrai Pimolmas

Technical staff

1. Mr. Bunlue Sreepichai Architect
2. Mr. Ekkapong Fangeon Engineer
3. Mr. Tanin Rodhuey Site Reporter
4. Mr. Prasarn Suktum Site Reporter

English manuscript

Dr. Sen Keyote